

Module 1 Honeybee Management

Introduction

This document is an updated reference used as part of Mid Bucks Beekeepers Association study group preparation for the BBKA Module 1 examination. When studying please do not use this document as the only reference source as the intention is that the contents be used as an aide memoir. As we all know if you ask 6 Beekeepers the same question you will get 6 differing answers all of which will be right so do not blindly trust what written here.

The information included in the document has been drawn from a multitude of sources. The sources include:

Guide to Bees and Honey	Ted Hooper
The Honeybee Around and About	Celia F Davies
BBKA News	
Beecraft	
MidBucks Beekeepers Association Study Group	

Internet

- britishbee.org.uk
- dave-cushman.net
- thorne.co.uk
- en.wikipedia.org/wiki/Beekeeping
- google

The contents of the document follow the syllabus of Module 1 as defined by BBKA.

Module 1 Honeybee Management

Contents

The Candidate shall be able to give a detailed account of:-

Contents	2
1.1 the types of hives and frames used by beekeepers in the United Kingdom,including comparative knowledge of the following hives, National, WBC, Smith, National Deep, Commercial, Langstroth and Dadant. (details of exact frame sizes will not be required);	4
1.2 the principles which govern the design of hives and frames, including the concept of bee space, and the main features of their construction;	8
1.3 the use of wax foundation;	10
1.4 Methods of fitting frames with wired and unwired wax foundation;	11
1.5 ways of getting wax foundation fully drawn;.....	13
1.6 the methods of spacing frames in hives, the usual measurements used and the advantages and disadvantages of varying the spacing;	14
1.7 the need for regular comb replacement in the hive and how this can be effectively carried out;.....	16
1.8 how to begin beekeeping, including the acquisition of bees, sources and type of personal and other equipment, the approximate costs of equipment and bees and any precautions necessary;.....	19
1.9 the criteria used in the selection of apiaries;	21
1.10 the factors to be considered in the siting of colonies in home and in out-apiaries;	23
1.11 good apiary hygiene;.....	24
1.12 the variable temperament of bees in relation to management and public relations; ..	27
1.13 the actions which can be taken to avoid bad-tempered bees causing a nuisance to members of the public;.....	28
1.14 the year's work in the apiary and how this is dependent upon the annual colony cycle and the timing of local bee forage;.....	29
1.15 the drifting of honeybees, the dangers caused and techniques used to minimise the problem;.....	32
1.16 the principles involved in feeding honeybees, including types of feeder, amounts of food, types of food and timing of feeding;	33
1.17 the value of honey, pollen, water and propolis to the honeybee colony;	36
1.18 the prevention, detection and control of swarming;	39
1.19 the use, and types, of queen excluder used in the United Kingdom;	40
1.20 methods of swarm control used in small-scale beekeeping enterprises;	41
1.21 methods of marking and clipping queens.....	44
1.22 the methods of making nuclei and the uses to which nuclei can be put;.....	46
1.23 how swarms and nuclei can be turned into productive colonies;	50
1.24 methods of taking and hiving a swarm of honeybees;	51

Module 1 Honeybee Management

1.25 the methods used to unite colonies of honeybees, the underlying principles of these methods and any precautions that should be taken;.....	53
1.26 robbing by honeybees and wasps and the associated dangers, including prevention and curtailment;	55
1.27 spring management of honeybee colonies;	56
1.28 management of honeybee colonies for honey production from oil seed rape and other specialist crops such as heather;.....	59
1.29 summer management of honeybee colonies;	60
1.30 moving colonies and the difficulties and dangers involved;.....	61
1.31 different methods of 'clearing' bees from supers;.....	63
1.32 how colonies are prepared for the winter period and the principles underlying this preparation;.....	65
1.33 the effect of honeybee stings and recommended first aid treatment.....	67
1.34 laying workers and drone laying queens and the conditions leading to their development;	69
1.35 the signs of queenlessness and a method of confirming the condition;	70

Module 1 Honeybee Management

1.1 the types of hives and frames used by beekeepers in the United Kingdom, including comparative knowledge of the following hives, National, WBC, Smith, National Deep, Commercial, Langstroth and Dadant. (details of exact frame sizes will not be required);

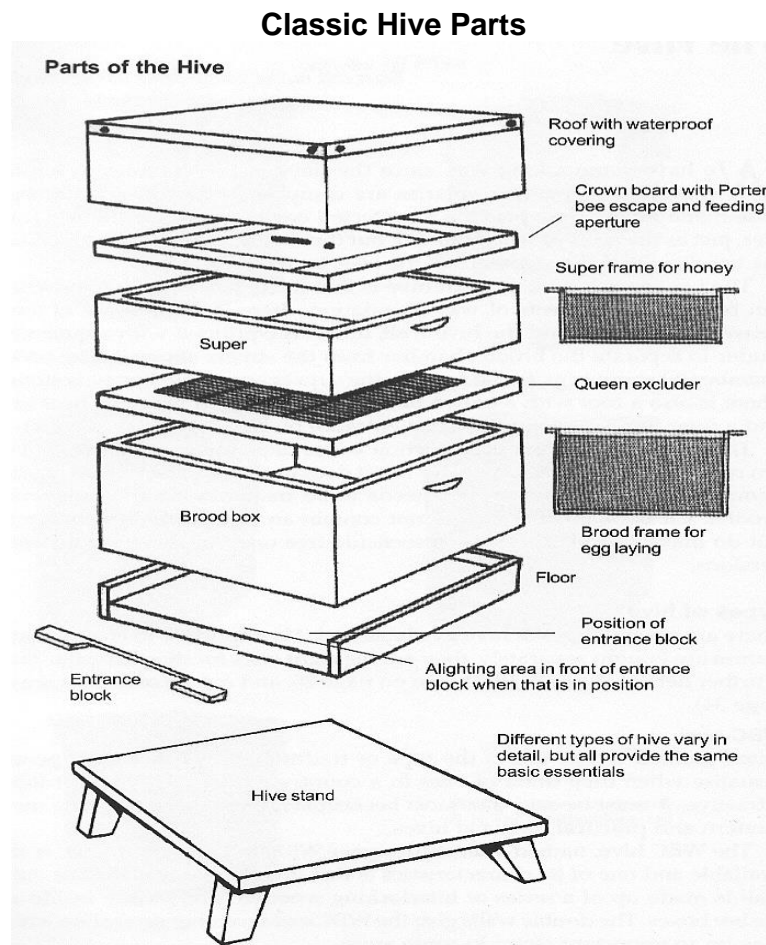

Modified National

The National hive is the most widely used hive in the United Kingdom. It is a square hive, with rebates (grooves) that serve as hand grips. The frames are smaller than standard Langstroth and Commercial hives and have longer hand grips (or "lugs"). Many beekeepers now view the brood box of the National as too small for the laying activity of modern strains of queen bee – so many beekeepers operate the National with a brood box and one super. This is sometimes called "a brood and a half". While this provides enough room for the brood, it also increases the number of frames that have to be checked through regular inspection. Because of this the National hive brood boxes are also now available in a 14 x 12 inch size (known as the **Deep National**) which gives a brood size similar to the Commercial or Langstroth.

The 14 x 12 frames can also be employed on standard National Brood boxes with the addition of an Eke in order to increase the depth of the box.

The size of the brood chamber is important. Many of the non-indigenous strains of bees require large brood nests (60 to 70,000 bees) and may tend to swarm in smaller hives.

- Single walled

Module 1 Honeybee Management

- Hand holds
- Long lugs on the frames
- Designed for a colony that is no larger than 55,000 bees
- Complex structure to the boxes
- Simple to use and disassemble

Long lugs make the design of the box more complicated, but frames are easier to remove. Long lugs also have the disadvantage that they are easier to break off the frame when removing them from the hive for inspection when the bees have stuck them down.

Commercial

Commercial hives have very similar dimensions to the National hive, but instead of having a rebate the hive is a simple cuboid. Because of this the frames are larger and have shorter handles or lugs. The brood box is picked up using small hand holds cut into the external wall of the hive. Supers have this same feature, which can make them difficult to hold when full of honey. Some beekeepers use National supers on top of a Commercial brood box. Brood chamber can contain up to 70,000 bees.

Smith

The hive is named after W Smith of Peebles, Scotland, the frames have the same surface area as the National however they have small lugs and hence a smaller box. This configuration is preferred by bees farmers in the that region.

- Single walled
- Short lugs
- Simple structure to the boxes
- Most common in the North
- Brood chamber appropriate for 55,000 bees

WBC

The WBC, invented by and named after **William Broughton Carr**, is a double-walled hive with an external housing that splays out towards the bottom of each frame covering a standard box shape hive inside. The WBC is in many respects the 'classic' hive as represented in pictures and paintings, but despite the extra level of insulation for the bees offered by its double-walled design many beekeepers avoid it due to the inconvenience of having to remove the external layer (the lifts) before the hive can be examined.

- Double walled
- Long lugs on the frames.
- Small brood chamber suitable for colony no larger than 45,000 bees. Fiddly to use
- Good in cold winters

Module 1 Honeybee Management

- Pretty
- Often painted and can require a lot of maintenance

Langstroth

Named for their inventor, Rev. Lorenzo Langstroth, these hives are not the only hives of this style, but they are the most common. Langstroth patented his design in 1860 and it has become the standard style hive for 75% of the world's beekeepers. This class of hives includes other styles, which differ mainly in the size and number of frames used. These include Smith, Langstroth hive, Modified Commercial and Modified Dadant and the British Modified National Hive.

Langstroth hives make use of bee space, a characteristic of Western honey bees which causes them to propolize small spaces (less than 1/4 inch), gluing wooden parts together, and to fill larger spaces (more than about 3/8 inch) with wax comb, but to hold an intermediate space open for bees to pass through. His cleverly designed hive makes use of bee space so that frames are neither glued together nor filled with burr comb - comb joining adjacent frames.

- Single walled
- Short lugs
- Simple structure to the boxes
- Brood chamber appropriate for 61,000 bees

Dadant

Similar in construction to Langstroth with deeper frames, largest beehive available:

- Single walled
- Short lugs
- Simple construction
- Brood Chamber approximately 85,000 bees

Dartington (Long Hive)

The Dartington Long Deep hive holds up to 21 BS deep '14x12' frames (14"wide x12" deep) with an insulated dummy frame front and back. The body is raised to a convenient working height on long legs and supports four honey-boxes each holding 5 Manley honey frames or 6 BS shallow frames (14"x 5½").

The hive comes with a division board to divide the body into two separate compartments, each with an entrance at either end of the hive.

Module 1 Honeybee Management

Hive Type and external dimensions (inches)	Volume (litres)	Beespace/Lug Type	No. Brood Frames	Brood Frame external dimensions (inches)	Comb area on both sides (sq inches)	Total comb area	Max brood cells 25 per sq inch	Likely no. of laying cells (80% of available)
National 18 ¹ / ₈ x 18 ¹ / ₁₈ Brood 8 ⁷ / ₈ Super 5 ⁷ / ₈	36	Bottom/Long	11	14 x 8 ¹ / ₂	199	2,189	54,725	43,780
WBC 19 ⁷ / ₈ x 19 ⁷ / ₈ As per National	32	Bottom /Long	10	14 x 8 ¹ / ₂	199	1,990	49,750	39,800
Smith 16 ³ / ₈ x 18 ¹ / ₄ As per National	36	Top/Short	11	14 x 8 ¹ / ₂	199	2,189	54,725	43,780
Deep National 18 ¹ / ₈ x 18 ¹ / ₁₈ Brood 12 ¹ / ₂	51	Bottom/Long	11	14 x 12	292	3,212	80,300	64,240
Commercial 18 ⁵ / ₁₆ x 18 ⁵ / ₁₆ Brood 10 ¹ / ₂ Super 6 ³ / ₈	48	Bottom/Short	11	16 x 10	275	3,025	75,625	60,500
Langstroth 20 x 16 ¹ / ₄ Brood 9 ⁷ / ₁₆ or 11 ³ / ₄ Super 5 ³ / ₄	44	Top/Short	10	17 ⁵ / ₈ x 9 ¹ / ₂	272	2,720	68,000	54,400
Dadant 20 x 18 ¹ / ₂ Brood 11 ³ / ₄ Super 6 ⁵ / ₈	59	Top/Short	11	17 ⁵ / ₈ x 11 ¹ / ₄	340	3,740	93,500	74,800
Dartington 36 ¹ / ₄ x 18 ¹ / ₈ As Deep National	124	Bottom/Long	21	14 x 12	292	6,132	153,300	122,640 (overstated as usually run at half capacity)

Module 1 Honeybee Management

1.2 the principles which govern the design of hives and frames, including the concept of bee space, and the main features of their construction;

The principals which govern the design of hives and frames:

- Size of colony, the hive must have the space to house the size of colony that the beekeeper intends to have, different species will result in different colony populations e.g. colony of Italian bees can be as large as 55,000 whereas UK native bee is closer to 45,000. If the hive is too small the colony will be prone to swarming.
- Ease of use, components of the hive must be easy to manipulate in terms of construction as well as weight, a super containing 20 frames may be a good idea but the weight when full will be beyond the capability of most beekeepers.
- Water tight design and materials, the bees need a water tight environment which at the same time is breathable, entrances need to be of manageable size (by the bees) allowing free flow of bees when busy as well as being defendable when required. UK beehives are made of cedar wood which means minimal maintenance whilst remaining weatherproof and durable.
- Employ standards, beekeepers have enough work managing their apiaries, by employing standards the hive can utilise such things as frames and foundation readily available from Beekeeping suppliers. Plus the added advantage that moving bees from one type to another is made simple through use of standard frames.
- Life cycle of bee, the design needs to separate the queen from the stores thus preserving their quality for sale, the brood area in which the queen is contained should be able to accommodate her lay rate in peak season and the pathway to the stores area is simple and enables workers to pass unhindered. The frame design and layout should match the bees natural tendencies in terms of comb building and storage of honey.
- Management of disease, features to assist in managing disease such as open mesh floors need to be incorporated into the design.

Key principle of design however is bee space, it governs the separation of frames, the spacing vertically between frames and the sizing of excluders to separate Brood and Honey Storage areas (supers).

- Bee space is a gap between 6 and 9mm within the hive

There is much debate about Top or Bottom bee space, here are some points worth thinking about:

Bottom Bee Space

- gives the ability to place boxes (supers) on flat surface without harming bees
- easier to remove frames as top of frame flush with top of box
- gives space for drone brood along the bottom of the frames

Top Bee Space

- safer for bees when replacing boxes
- cover boards and feeders can fit flush to top of box

Below is a summary of the dimensions relating to "Bee Space"

Bee space is either 5.3 mm + or - 0.5 mm or it is 9.0 mm + 0.0 mm - 1.0 mm. In other words there are two distinct bands of possible bee space and these occur because in some situations the bees will work individually but in other situations they need to be able to work back to back.

A gap of less than 4 mm. is too small for any but deformed worker bees to pass through. Any spaces, cracks or crevices of this or smaller dimension will be filled with propolis or sometimes a mixture of wax & propolis and on yet other occasions pollen may be mixed in with the filling (I suspect that this is for reasons of porosity or possibly the transmission of light, but I am not certain).

A gap of 4.3 mm is a standard European spacing for wires in a Queen Excluder.

A gap of 5 mm if used between the wires of a square mesh will make an excellent pollen stripper as the

Module 1 Honeybee Management

workers can get through but a significant portion of pollen will be stripped from their legs.

A gap of 5.2 - 5.4 mm is a spacing that can be used to exclude or differentiate Drones as Workers and Queens will pass but Drones cannot.

A gap of 6 mm is the smallest gap that bees will leave between adjacent comb surfaces (outside of the usual clustering area) the bees can defend this more easily and they can work individually within this dimension. The smaller gap around the periphery of the nest, also renders the nest less susceptible to draughts, and may help in maintaining humidity.

A gap of 7 mm not used by the bees themselves but some people regard it as a valid bee space to use in some parts of beekeeping equipment. If this spacing occurs between the side faces of frame topbars they are the least likely to suffer from accretions of wax. Frames spaced at 35 mm pitch (normal Hoffmann spacing) that have topbars 28 mm in width give rise to this 7 mm gap.

A gap of 9 mm is the usual space the bees will leave between adjacent areas of capped brood this allows two layers of bees to work back to back, usually in an oval pattern in the centre of a frame.

A gap of more than 9 mm and we are into brace comb territory!

A Gap of 10 mm is practical from a design point of view. with the B.S. Brood frame at 215 mm (some are 216) mm and the Shallow Frame at 140 mm The boxes are then 225 mm and 150 mm respectively this gives 1 mm above the frames and 9 mm below (or the reverse if top bee space oriented). This may seem large but it only is this way with fresh equipment. The grain in the frame side bars is vertical and practically no shrinkage will occur in this direction. The box sides however are grain oriented horizontal and the shrinkage will occur in the vertical height of the box. So in use the space is often much less than the initial 10 mm.

In all things there are exceptions, when it comes to the gap between the frame bottom bars in the bottom box and the floor surface underneath it, this is usually 28 mm or 31 mm in UK hives, but it does not suffer brace or burr comb unduly, as the bees consider it a similar situation to a wild nest in a cave.

Module 1 Honeybee Management

1.3 the use of wax foundation;

Wax foundation is used to encourage bees to draw out comb to cover the full surface area of a frame.

Wax foundation provides a template for the workers to draw out the comb, ensuring that the comb ends up where the beekeeper wants it, the drawn comb fills the whole area of frame so optimum use is made of the space available and the size of the template dictates the use of the comb e.g. in brood for queen to lay worker eggs.

- Foundation is a wax template mounted within a moveable frame in the hive, the template is embossed with the cell pattern that the beekeeper would like the bees to follow when drawing out the comb in the brood chamber of supers
- this encourages bees to build the desired (worker or drone) sized cells in an orderly manner across the whole available surface
- Facilitates easier manipulation and inspection of bees
- Foundation can be specific to drone or worker cells being drawn out by the bees, this is done by using different cell size templates on the foundation
- The foundation can be wired or unwired

Module 1 Honeybee Management

1.4 Methods of fitting frames with wired and unwired wax foundation;

Directions for fitting frames

Inside the hive there are frames (usually bought and assembled by the beekeeper). The frames are designed to hold standard sizes of wax foundation. This foundation gives the bees an ideal start for building honeycomb that is then used to breed bees or store food for the colony (and the beekeeper). There are many designs of frames and beginners should get advice from the local beekeepers on the most appropriate in their area and for their design of hive.

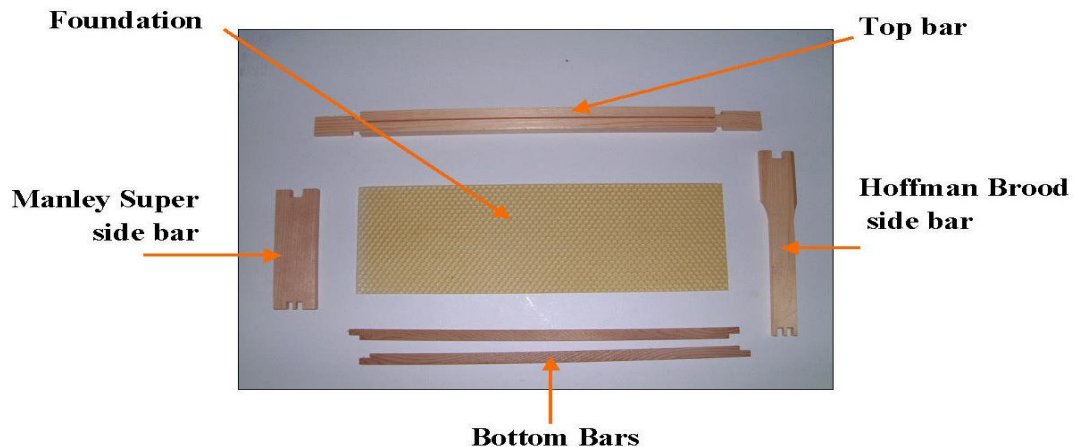

The picture shows the main components of the frame and how they are assembled.

Below is a completed frame showing the positions of the nails.

Frame with pins in the correct position

Position of pins are marked by arrows

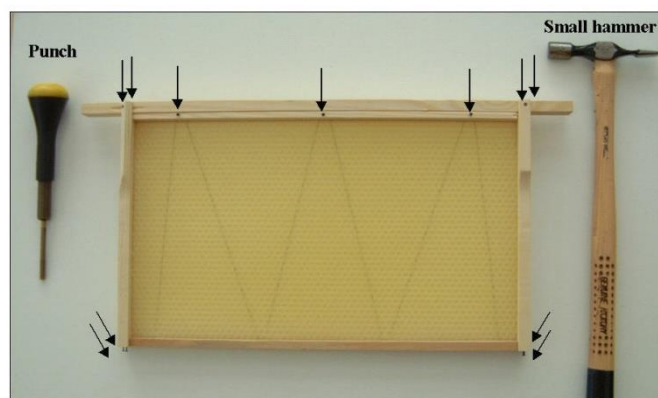

Brood frames and super frames are made in the same way but the brood frames are deeper and often have self-spacing side bars. The top illustration shows the Hoffman design. The advantage of this is that it maintains the correct **bee space** between the frames.

The value of the Manley frame within the supers is it provides flat sides for cutting off the cappings.

It is important that the foundation is fitted so that it is flat and parallel with the sides of the brood chamber.

Module 1 Honeybee Management

Foundation can be wired or unwired. Brood foundation is normally wired to give it sufficient strength but unwired foundation can be used in supers if you want to produce cut comb.

Module 1 Honeybee Management

1.5 ways of getting wax foundation fully drawn;

Honeybees employ a lot of energy in the production of wax and drawing out foundation. In fact it takes approximately 10 times the energy to produce wax as it does to produce honey. Therefore to be guaranteed good wax production there must either be a good flow or the bees require to be fed with 1:1 sugar syrup.

In order to draw out foundation the honeybees require heat, they do this by clustering and festooning on the comb. Foundation is always drawn out above/around the brood first it takes advantage of the heat generated in the management of the brood.

Bees will not draw out comb unless they need it (for stores or expansion of the colony) so unless there is a need foundation will not be drawn. Plus the colony must be strong in numbers and particularly of young bees of the right age to produce wax.

A swarm is primed and ready to draw comb, it has 70% young bees and is motivated to build a new home. If homed in a brood box of fresh foundation and fed well (taking the appropriate precautions first) it will draw out all available frames with perfect fully drawn foundation very very quickly.

Some approaches to achieving fully drawn wax foundation:

1. mix fresh foundation with foundation already drawn, placing the fresh foundation in the centre of the super
2. Feed the colony to encourage brood development and provide honeybees with a source of energy
3. Use narrow spacing between frames to encourage the bees to draw the comb across the whole frame
4. Hooper talks about removing the queen excluder in order to encourage the bees to move up to a new super, making sure if the queen moves up and starts to lay she is put back in the super swiftly and the queen exclude replaced
5. Do it at the right time of the year, early spring is too soon as mainly winter bees in the colony, August is too late as bees more concerned about laying down stores
6. If colony small rest available space to encourage bees to draw out available new foundation
7. In brood box when building up the colony do not fill box with fresh foundation, build it up as needed, this encourages the full frame to be drawn out

Module 1 Honeybee Management

1.6 the methods of spacing frames in hives, the usual measurements used and the advantages and disadvantages of varying the spacing;

Frame Spacing

In feral colonies, bees space their combs at approximately 1 3/8" (35mm) between the midrib of adjacent frames. This leaves a space between the comb faces of 1/2" (13mm) allowing the bees to work back to back between the combs. Within bee hives, a number of methods are used to achieve the same constant space between combs.

Self spacing.

Hoffman brood frames have side bars designed to provide the required spacing of 1 3/8" although Modified Dadant brood frames are designed to space frames at 1 1/2" (Does anyone know why?).

Frames with plain side bars (DN1, DN2, SN1, SN2) are not self-spacing and so need to be used with separate spacers. Whilst brood frames need to be spaced by the standard 1 3/8" it is possible, with care to use wider spacing for the frames in supers. This wider spacing, up to 2" between frames, allows a reduction in the number of frames required to fill the super as well as providing an increase in the weight of honey which can be stored. There are also fewer frames to uncap when the time comes for honey extraction and the thicker combs are easier to uncap as the comb surface stands proud of the frame.

There are several ways that frames can be spaced:

Metal/Plastic Ends

Metal ends, which slide onto the lugs of National or WBC frame top bars were introduced by WBC in 1890. These are still available, but have largely been replaced with plastic equivalents. Plastic spacers have the advantage of being less likely to result in cut fingers. Spacers are available in two sizes, narrow to provide the standard spacing of 1 3/8" or wide for use in supers where it is desired to space frames further apart (up to 2"). They are also available in a range of colours corresponding to the queen marking colours. Some beekeepers use coloured plastic ends to help identify the age of combs to assist with their comb replacement programme. Another technique is to use one colour of spacer on one end of the frames and a different colour on the other end to help ensure that frames are always replaced in the box the correct way round.

Castellated runners

These are fitted to the box, usually in place of the frame runners. They are available to suit spacing for 9, 10 or 11 frames in a National super. They can be used in brood boxes but in that case the appropriate castellation must be selected to maintain the standard spacing of 1 3/8".

Studs/screws

Some beekeepers use round head screws or studs (Brother Adam of Buckfast Abbey used hob nails) to space frames accurately. These methods are not widely used due to the labour involved in fitting the spacers but they do have the advantage of minimum contact-area between the frames, which reduces the use of propolis by the bees. Time consuming method and costly relative to gain.

Yorkshire spacers

Metal spacers that fix onto the frame side bars. They are not commonly used these days, having been largely superseded by the more popular Hoffman frames. Sharp edges can be a problem

Finger spacing

This relies on judgement using a finger at each end of the top bar and checking that the frames are equally spaced across the brood box. Not to be recommended as a method to be adopted as the norm, as it is not possible to achieve accurate and consistent spacing, but useful in an emergency if you run out of plastic ends or are unfortunate enough to have a mixture of plain and self spacing frame types in the box.

Module 1 Honeybee Management

Comparison table

Each of the spacing methods available has advantages and disadvantages. There is no single ideal method which will suit everyone. The following table compares some of the advantages and disadvantages of each method.

Spacer Type	Advantages	Disadvantages
Metal/Plastic ends	Low cost, can vary the spacing in supers	Need to be removed from super frames when extracting
Hoffman	Self spacing	Frames more expensive, side bars may not fit extractor
Castellated spacers	Do not require plastic ends on the frames, available in a range of spacings, prevent frame movement during transport	Can have sharp edges
Manley	Prevents frame movement during transport	Cost, bees propolise frames together

Module 1 Honeybee Management

1.7 the need for regular comb replacement in the hive and how this can be effectively carried out;

The prime reason for the need for regular comb replacement in the hive is as part of the hygiene management of the colony. Comb change within in the brood box is an acknowledged method of managing the spread of brood diseases.

It also assists in curtailing infestation by the wax moth. Wax moth feeds on the detritus of old pupae skins and the like within the brood nest, replacement of comb reduces the amount of old comb that the wax moth can feed upon.

Comb can become distorted and unusable and needs replacing.

Over time the cell walls thicken through repeated cleansing by house bees, comb replacement avoids this becoming an issue.

As a rule of thumb all brood comb should be replaced within a hive every three years. Below are different methods for carrying this out:

Gradual Change

In the Autumn move the old brood frames that you wish to replace in the Spring to the outer edge(s) of the brood nest. If warm way to the rear of the nest and if cold way to either edge.

In the Spring as the colony starts to build up remove the old frames and replace with new frames and foundation. Feed as necessary.

3-4 brood frames can be replaced each year this way.

Shook Swarm

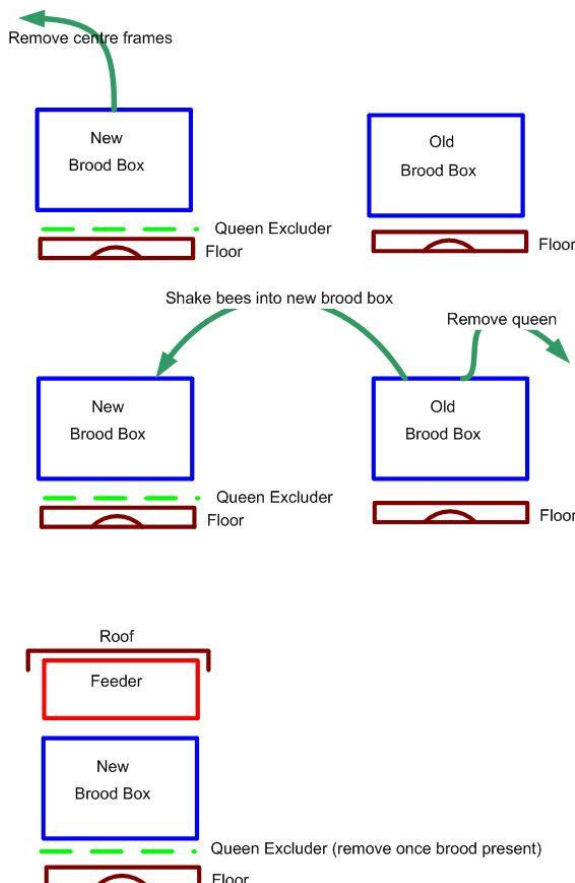

This should be carried out on a strong colony, say bees covering 5-6 frames with all stages of brood, during warm weather. The colony will need feeding even if there is a strong flow.

Move the hive to one side and replace it on the original stand with a new brood box with new foundation. Above a queen excluder.

Remove the centre frames from the new brood box. Find the queen in the old hive and make her safe.

Going through the original hive frame by frame shake all the bees on the frame into the new box. Brush any remaining bees into the new hive.

Introduce the queen into the new hive, close up the hive and feed. Remove the bottom queen excluder once all stages of brood are present. Destroy old comb.

Points to note:

- Do not carry out Shook Swarm if colony suffering from Nosema as the act of shaking bees will cause them to defecate.
- All brood is lost
- Do not carry out too early in the season
-

Module 1 Honeybee Management

Bailey Comb Change (Spring)

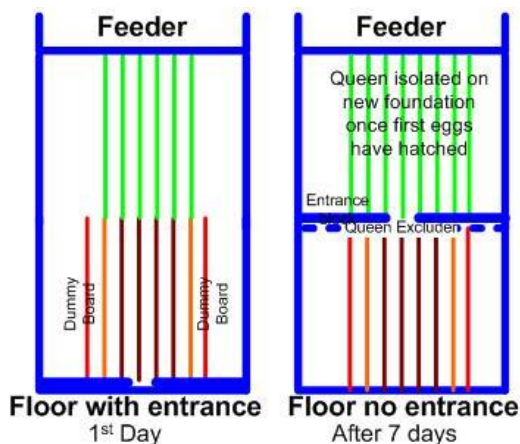

In the spring when the bees are foraging and the colony is covering 5-6 frames with up to 3 frames of all stages of brood remove all the frames without bees on. Dummy up the colony so that it is space restricted.

Place a second brood box directly above the colony with fresh foundation placed over the frames in the bottom box. Feed the colony.

After about 7 days check the top brood box for drawn comb, brood including larvae and the queen. If larvae present the queen should be isolated by placing a queen excluder between the brood boxes.

Close off the original entrance and place a new entrance above the queen excluder.

Continue to feed.

As the colony grows in the new brood box add new frames of foundation.

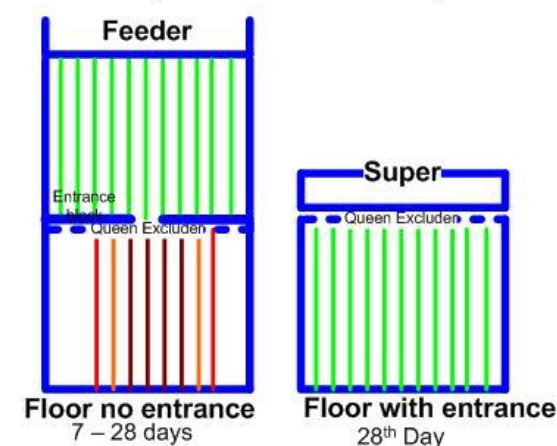

After 7 days check the original brood box for queen cells, tear down any that are present. 21 days after the queen excluder was inserted remove the bottom brood box and queen excluder.

The original entrance can now be used. Destroy the old comb.

Bailey Comb Change, Weak Colony

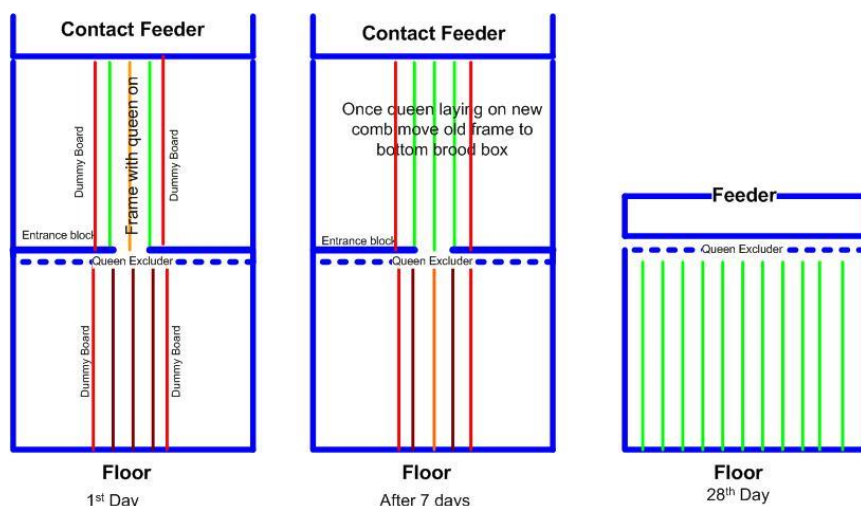

Remove all frames except for those with brood on.

Find the queen, place her and the frame she is on in a new brood box above the original.

New brood box above queen excluder and new entrance. Close off old entrance.

Sterile drawn comb placed either side of queen frame in top box. Both brood boxes are dummied down. Feed via contact feeder, thick sugar syrup 2:1. Combs in both boxes directly above each other.

Once queen is laying on sterile adjacent comb move old frame to the bottom box, isolating the queen in the top box.

Continue to feed, add additional frames of foundation as necessary.

After all brood emerged from bottom box (up to 28 days from start) remove it and destroy comb.

Module 1 Honeybee Management

Comb Change, Strong Colony (Summer)

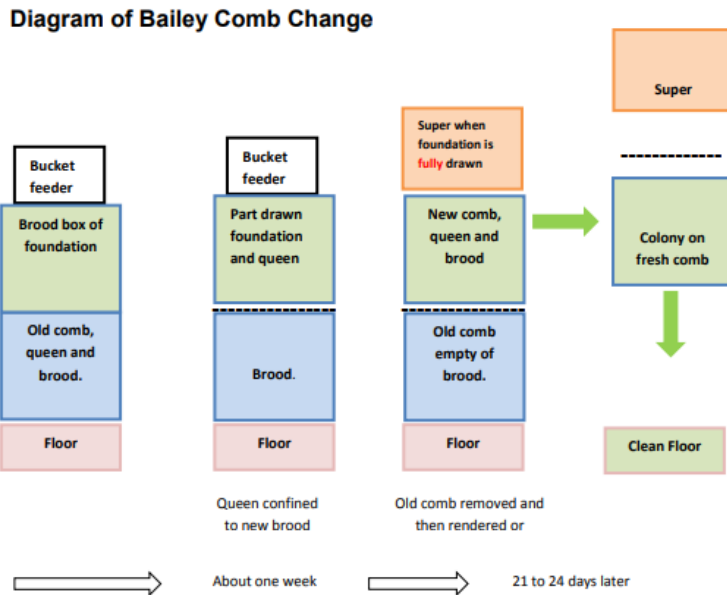

©Crown copyright NBU Replacing Old Brood Comb Oct 2014

Follow the same procedure as Bailey Comb Change in Spring except:

- Do not dummy down the brood box
- Do not remove excess frames
- Place a full set of frames in the new brood box
- Depending on the flow may not need feeding
- Leave supers above queen excluder over the top brood box

Module 1 Honeybee Management

1.8 how to begin beekeeping, including the acquisition of bees, sources and type of personal and other equipment, the approximate costs of equipment and bees and any precautions necessary;

Gather information before committing:

- Read a few books about beekeeping, e.g. BBKA Guide to Beekeeping by Ivor Davis and Roger Cullum-Kenyon
- Join a local Society (info from BBKA or Google search)
- Take a Basic Beekeeping course and attend local meetings
- Ideally have an experienced beekeeper as a mentor

Decide whether to begin beekeeping with a nucleus, colony or swarm.

The first 2 can be purchased and acquired at virtually any time of the year. Whereas a swarm can be obtained during approximately May – August !!

The ideal approach is start with an over-wintered nucleus after attending a Beekeeping Course over the winter. This will allow the beginner to see a nucleus expand and become a colony and hopefully reap a honey harvest in the 1st year.

A large colony can be daunting to begin with and starting with a swarm has problems:

- Bee's temperament is unpredictable
- Risk of importing infection
- Availability is unpredictable

It is best to obtain your bees from a reputable source with some guarantee of quality:

- The best bees have good tempers
- Are non-following out of the apiary
- Are still on the frames during inspections

Equipment needed:

- Decide on your type of hive – most beginners use National. The traditional WBC hive looks very pretty but is expensive and heavy to handle.
- Solid wide base to place the hive on 15 to 18 inches off the ground
- Complete list
 - Hive floor (open mesh with entrance block)
 - Brood box
 - Brood frames and foundation
 - Most beekeepers use Hoffman self-spacing type of frames
 - You need 11 frames per box and they come in packs of 10!
 - Dummy board
 - Super box
 - Super frames and foundation
 - Crown board with bee escapes
 - Roof
 - Cuprinol clear preservative for hive boxes
 - Smoker
 - Bee suit (white smooth textured is best)
 - Gloves
 - J-shaped hive tool
 - Queen excluder
 - Wellies – to protect ankles and stops bees climbing up trouser legs
 - Bucket and washing soda
- Items you will need later:
 - Spare hive to be able to artificially swarm
 - 2nd and 3rd Super (plus frames and foundation)
 - Nucleus box
 - Eke

Module 1 Honeybee Management

- Mouseguard
- Feeders; Contact, Miller, Ashforth and frame feeder
- Candy for winter feeding
- 2nd Bee suit for use when visiting other apiaries or when your suit is laundered

Costs

Nucleus of Bees £ 150-250 (Cheaper from local supplier)

Hives

The complete National Hive made from Red £411.50
Western Cedar supplied flat packed

- Open Mesh floor - ready assembled
- Brood body with 11 DN4 frames and dummy board
- Stainless steel wire queen excluder
- Two supers with 10 SN1 frames on castellations
- Crownboard with two plastic porter bee escapes
- 4" roof
- Glue and nails

plus:

- the book, Bees at the Bottom of the Garden by Alan Campion
- Getting Started leaflet
- standard galvanised smoker
- jacket and veil
- pair of mordant leather gloves
- record card
- mouseguard
- bee brush
- stainless steel hive tool
- english feeder

These prices are for the Thorne's Beginners Starter kit, there are plenty of other providers. These range from bee publications, internet and second hand sources. Although a new beekeeper needs to be extra careful about obtaining second hand woodwork . It may be incompatible or worse carry disease.

Precautions

- Is there anyone likely to come in contact with your bees who is highly allergic to be stings
- Obtain bees from a reputable source
- Think carefully before buying second-hand equipment. Risk of not fitting together and of course possible infection
- Beekeeping is time consuming
- Not a cheap hobby
- Locate hives carefully: remember access, neighbours and vandalism threat
- Learn how to handle your bees. Keep records. Observe hygienic rules of management
- Be a responsible beekeeper

Module 1 Honeybee Management

1.9 the criteria used in the selection of apiaries;

Consideration for the public.

The general public are often ignorant and frightened of insects. If they become alarmed about the presence of bee hives, their complaints can result in your bees being considered a 'nuisance' with the consequent loss of apiary sites for yourself and other beekeepers. Bees establish regular 'flight paths' en route to adjacent forage. Enclosing an apiary with hedges or a trellis to lift them above head height is good practice. This also reduces the visibility of beekeeper activity.

Avoid sites which border roads or public paths especially bridleways, where mounted riders may pass.

Keep only good tempered bees. Culling bad tempered stock and replacing with more docile strains is beneficial to both beekeeper and public.

Damage to hives from thieves and vandals can occur, so hives need to be well guarded or unobtrusive. Out of sight out of mind is a good maxim.

Forage

Honeybees mostly forage for both nectar and pollen within a kilometre of their hive and up to about five kilometres for exceptionally rewarding sources. An apiary site may be permanent, where forage during all growing seasons is desirable, or temporary to exploit a crop or seasonal source such as oil-seed rape, lime, heather or Himalayan balsam. Arable farmland may provide an excellent source for a month but then nothing for the rest of the year. Gardens are usually planted with year-round flowering plants, shrubs and trees. An apiary within flying range of these but sited in an area of low population density can be ideal.

It is a good idea to find out the location and size of other apiaries that might provide competition for forage in the area. Talk to members of your local association who may be able to help. There are no problems with small numbers of hives and vast farm crops but field margins and gardens provide much smaller though continuous forage. It is sensible not to compete with large beekeepers.

Environment

The hives should be sheltered from the prevailing wind, so that foragers can land easily at the hive entrance and roofs are not blown off in gales. Avoid sites open to cold northerly or easterly wind.

A generally southerly aspect will provide warm and dry conditions, especially helpful in winter.

Avoid sites in a frost pocket which will check spring development or on low or damp ground that could become flooded.

Sites under trees are unsuitable because they are usually damp.

The area should be fenced from livestock which may kick over hives.

Bees need water to dilute honey stores for use in spring and to cool the hive in hot weather. If this is not naturally available then consideration should be given to providing a suitable source, away from the main flight paths to avoid fouling.

You may find it helpful to discuss potential sites with your local bee inspector, who can advise if there are any disease problems in the area.

Access

Convenient access is essential. Easy movement of equipment in and out of the apiary ensures that your routine inspections will be productive. Adding and removing supers, controlling swarming, feeding and treating the colonies is a pleasure when it is not physically demanding or hazardous.

Do not consider a site which entails climbing fences or crossing ditches to enter. It is ideal to have vehicular access right up to the hives when necessary. Remember, dry grassland may become impassable mud in wet weather.

Module 1 Honeybee Management

A level site is easier to manage

Space

It is sensible to increase the number of hives envisaged, by at least two to allow for contingencies. Then make measurements and a rough plan of the site to confirm that you will have sufficient space.

Guidelines when making the plan.

- It is vital to have access to manipulate the colonies within the apiary, without working in the flight paths.
- It is more ergonomic if the orientation of the frames in the hive are across your body from where you plan to stand.
- There should be space to stack the removed supers and roof without the beekeeper moving away from the hive.
- Placing the hives on stands about 35 cm above the grounds makes for a comfortable working height for the beekeeper.
- The hive entrances should face in different directions to avoid drifting of bees between hives.
- Allow a distance of at least two hive widths between each hive.

Public	Forage	Environment	Access	Space
Minimise risk of anyone except beekeeper getting stung	Adequate forage within viable flying distance (up to 3 miles)	Weather and other occupiers of the site	Ease and Convenience	Safety and convenience
Hives should not be in plain view – increased anxiety, risk of theft	What forage is available and at what times? E.g. early and late pollen	Shelter from wind Southerly aspect Shade from midday sun	Close enough to be easy to carry out visits	Room to move and stack boxes
Flight paths not to cross pedestrian walkways (includes height)	Trees Gardens and or crops Cereals not helpful	Avoid tree canopies and frost pockets	Flat level site Not prone to flooding	Don't have to stand in flight path
Keep good tempered bees	Competing bees? Are there too many hives in apiary	Availability of water Avoid using neighbours ponds and bird baths	Vehicular access up to hives or at least wheel barrow access	Space to position hives properly so as to avoid drifting
Security, avoid risk of damage by humans		Security, fence to protect from livestock/domestic and wild		Space for two hive widths between each hive
Permission to use site, check if allowed on allotment		Consider swarming and allergies for neighbours		

Module 1 Honeybee Management

1.10 the factors to be considered in the siting of colonies in home and in out-apiaries;

Factors to be considered in selecting an Apiary site:

1. Will the site cause a nuisance to neighbours or the general **public** ? Is it safe from vandals?
2. Is there **forage** for the honey bees? Are there any apiaries nearby?
3. Is the **environment** of the site suitable for bees?
4. Is there convenient **access**, with minimal carrying for the beekeeper to bring in equipment and remove honey supers?
5. Is the **space** suitable for the number of hives envisaged?

Situations to avoid

- A small suburban garden, adjacent to areas where children play may cause instant complaints, when a beekeeper clad head to toe in protective gear ventures forth to inspect a newly sited colony.
- A cloud of roaring bees swarming into a neighbour's garden.
- Bees drinking at neighbours bird baths or garden ponds.
- Bees soiling the neighbours washing as they make their cleansing flights in early spring.
- A hive on a flat and possibly slippery roof accessible either by ladder or through an upstairs window!

Finding the site

Establishing good relations with neighbours, local farmers, land owners and the general public is a major factor in finding and maintaining a successful site for your bees. Talk to them about the value of bees as pollinators; educate them about swarms, flight paths etc. Try to capture their interest and co-operation, gaining respect for the bees and the beekeeper.

Most beekeepers are tempted by the familiar and convenient location of their **own garden** where they can watch their bees at work and attend to them easily, but small gardens, particularly those surrounded by houses are not likely to be a successful solution. With careful management a small garden in open countryside or a garden at least the size of a tennis court could provide a suitable site for two or three hives.

In the **country-side** local farmers and gamekeepers can be very helpful in finding a good site. You may have noticed an attractive situation; it is the farmer who will direct you to the owner whom you must approach for permission to use the site.

The traditional payment for use of an apiary site is a pot of honey per year per hive although other agreements may be reached.

If your selected site is not possible you will usually be offered a choice of other sites. It is then that you must be quite clear and single minded about the criteria for a satisfactory site. Visit the possible places with a beekeeping friend and discuss the points reviewed in this leaflet. It will be time well spent. Moving site is no joke.

In Home	Out Apiary
Accessibility to stored equipment	Physical allergies or psychological worries – away from neighbours
Able to easily view hives to monitor activity	Potential for larger number of hives
No travel costs and less time taken	Possible better forage
Potentially more security	Able to choose better crops for forage e.g. borage fields

Module 1 Honeybee Management

1.11 good apiary hygiene;

The purpose of good apiary hygiene is to prevent the spread of disease between honey bee colonies and so maintain healthy bees. Good hygiene can also help to ensure the production of unadulterated honey. Low levels of disease are not always recognised and their presence can stress bees, making them even more susceptible to other diseases. A wide variety of diseases can be avoided by adopting hygienic practices.

Disease transmission and its prevention.

The major agent in the spread of brood diseases is the beekeeper.

If any contaminated combs or hive equipment are transferred to a healthy colony it becomes infected.

- Avoid moving frames between hives, this includes both brood and super frames.
- Replace supers after extracting back to same hive for cleaning
- Keep all equipment (hive tools, queen cages, brushes etc) as clean as possible, as explained later.

Beekeepers could introduce pathogens or chemicals into the honey.

The risk is low but causing human disease has a high public profile.

- When manipulating hives, avoid placing frames or supers on the ground or grass to minimise the chance of contaminating honey or wax.
- Wash your bee suit and boots regularly to remove pathogens and promote a clean image of beekeeping.
- Be scrupulous in following the instructions provided with veterinary products and use only those which have low risk of contaminating the products of the hive.

The bees also have a part to play.

Bees attracted by the scent of honey will rob out weak infected colonies and forage round dirty comb and equipment left lying around carrying the infection back to their own hive.

- Don't leave old combs or wax lying around near hives, always collect it into a container that can be closed and remove it from the area of the hives keeping it sealed.
- Seal hives where colonies have died. Move well away from flying bees, dismantle and treat as in 3c, also burning the dead bees.

In certain circumstances bees alone can transport infection.

Although worker bees usually stay with their parent colony, drones do move from hive to hive. Drifting of infected workers can occur and carry infection to neighbouring colonies.

- To minimise drifting hives should be arranged to enable the bees to find their own colony with ease. It helps to have coloured roofs and entrances facing in different directions
- They should be well spaced. (1.2 to 1.5 metres) suggested.

Bees from another apiary could bring in disease.

Swarms from an infected hive may carry infection and become diseased after they have been hived.

Bees from a colony infested with varroa have been known to abscond and take refuge in neighbouring hives.

- Swarms of unknown provenance should be housed in an isolation apiary on new foundation and not fed for 48 hours so that all the honey they carry is used for wax production. They should be treated for varroa and need to be kept in isolation until the health of the brood can be properly assessed.
- Regular monitoring of the drop rate of varroa in all colonies will alert the beekeeper to a sudden infestation. He can then take appropriate steps according to the season.

Inspection Routine.

- Take a bucket of washing soda solution to the Apiary to rinse tools and gloves between each hive. Use rubber or latex gloves as they can be washed easily. Replace regularly.
- Take a box with lid in which to put brace comb, propolis scrapings, queen cells etc and plastic sacks for frames that you need to seal off and remove from the site.

Cleaning and caring for equipment

Have a routine for separating used items needing cleaning from clean stock. Try to store all cleaned stock in a separate building.

- a. Clean all used equipment (supers, brood boxes etc) in between re-use. If solid floors are used or there is a solid sheet below the varroa mesh these should be changed and treated regularly. A blow torch is a convenient way of sterilising these wooden parts. Fumigation with Acetic acid or Sulphur dioxide is very effective if reuse is not urgent. Second hand equipment should be thoroughly sterilized before taking to the apiary and any second hand comb should be burned.

Module 1 Honeybee Management

- b. The wax from older super comb can be cut out and recycled and the frames boiled in soapy washing soda solution to clean and disinfect them. (An electric boiler or old tea-urn is a valuable piece of equipment for the bee-keeper)
- c. The wax from old brood comb should be cut out and destroyed by burning, preferably in an incinerator. Take care when burning a large quantity of wax as it is highly inflammable. The frames can be boiled in soapy washing soda solution as above.
- d. Super frames with clean unbroken comb should be preserved. Good quality drawn comb is a valuable asset for the beekeeper and must be stored carefully to avoid damage by wax moth or mould.
- e. Supers with good comb usually winter well if stacked outside with a queen excluder on the bottom and another as a crown board below the roof. This allows air to circulate but keeps out the mice. It prevents mould and allows spiders to get in to control wax moth. The freezing winter temperatures kill off the wax moth too.
- f. Brood comb is more susceptible to wax moth although about 5 days in a freezer then sealing the boxes containing the combs to avoid further infestation should solve the problem. Acetic acid, Certan or Sulphur dioxide can be used to disinfect and control wax moth. This treatment may need to be repeated during the winter.

Treatment agents for equipment.

Washing Soda [NOT caustic soda]

Used for washing tools, gloves, wooden frames etc. It helps to remove wax, propolis, and honey and is a mild disinfectant. Washing soda crystals are widely available and cheap. Make up a solution by dissolving 0.5 Kg in a gallon of water. Use with care; it is mildly corrosive.

Sulphur Dioxide

It is produced by burning sulphur strips, (obtainable from beekeeping suppliers) and is used for treating wax moth in stored combs. Six supers containing the frames are stacked and 2 strips placed in a metal container which is suspended from the top of an additional empty box. The strips are lit and the roof put on quickly. The fumes are heavier than air and will fall through the stacked combs. Avoid inhaling the smoke. Sulphur dioxide is not fat soluble and so its use poses very little risk to wax and honey.

Certan

Certan is a safe biological treatment for wax moth obtainable from beekeeping suppliers. It is a spore suspension of *Bacillus thuringiensis* which infects and kills wax moth larvae. It is mixed according to the instructions and sprayed on both sides of the frames. After drying, the frames are then stored in supers or brood boxes. It is fairly expensive. It has to be kept dispersed while spraying otherwise it can block the sprayer.

Acetic Acid

Used for sterilization of comb and boxes. Obtainable from beekeeping suppliers at strength of 80%. Make a stack of boxes and combs needing treatment. On top of each set of frames place an absorbent pad on a saucer or plastic tray and pour about a third of a cup of acetic acid onto the pad. Place a solid cover board on the top of the stack and seal all joints; packing tape is suitable. Let the fumigation proceed for about a week then air the combs thoroughly for another week.

Acetic acid is very corrosive. It will remove skin very quickly. Wear overalls, rubber gloves, eye protection and a breathing mask. Don't place the stack on a concrete or brick floor and remove metal ends.

Note

PDB (paradichlorbenzene) is **NOT** recommended and should not be used as the substance can accumulate in wax. Moth balls or any product containing naphthalene should NEVER be used as they are poisonous to bees

The key aims of good apiary hygiene are:

1. Preventing spread of disease
2. Helping to ensure the production of unadulterated honey
3. Minimising the nuisance factors to others

Module 1 Honeybee Management

Preventing spread of disease

- Avoid moving frames between hives
- Remove old brace comb, frames, supers etc. from the apiary promptly
- Keep clothing and equipment clean*
- Place hives in a manner that avoids drifting
- Seal and remove/sterilise hives from dead colonies ASAP
- Caution when bringing new colonies / swarms into the apiary
- Change comb regularly
- Do not feed imported honey

Helping to ensure the production of unadulterated honey

- Careful use of approved chemicals & treatments
 - prompt removal and disposal of spent treatment strips / packaging etc.
 - Note that Oxalic acid (unapproved) dissolves in Honey
- Do not use PDB or Napthalene due to the build up in wax and transfer to honey

Minimising Nuisance Factors

- Robbing bees & wasps cause nuisance in and around the apiary as well as the risk of disease spread & loss of honey. Remove supers and old comb from the apiary promptly.

*Cleaning

Washing soda – 0.5kg/gallon for frames, tools, gloves etc.

Sulphur Dioxide strips – fumigating combs for wax moth

Acetic Acid 80% - for sterilising combs against Noseama, EFB & also wax moth.

Module 1 Honeybee Management

1.12 the variable temperament of bees in relation to management and public relations;

Good Tempered Traits	Bad Tempered Traits
Behave calmly when hive is opened	Fly up and become defensive when hive opened
Do not follow you when you leave the hive	Run over the comb
Are not defensive if the hive is approached	Follow you when you leave the hive
	Become defensive when hive is approached
	Stress caused by disease or intrusion by beekeeper or others such as wasps

A colony may display one or all of these traits and may change behaviour throughout the year.

Factors contributing to temperament

- Genetics, crossing *Apis Melifera Linguistica* (Italian Bees) with local bees can improve temperament
- Presence/absence of forage
- Weather
- Ambient environment
- Interference by beekeeper

How the beekeeper can deal with temperament

- Requeen
- Cull
- Open up bad tempered hive last
- Do not open hive in bad weather
- Do not open the hive unnecessarily
- Manipulate gently with sensible use of smoke

Public Relations

- Do not carry out manipulations when neighbours/public are in the vicinity
- Move bad tempered colonies, or those giving cause for concern well away from public spaces, including gardens, footpaths and any areas regularly used by others particularly children
- Do not site any hive so that the beesflight path to forage or water supply is across an area used by others
- Ensure good water supply local to hives

Module 1 Honeybee Management

1.13 the actions which can be taken to avoid bad-tempered bees causing a nuisance to members of the public;

- Choose an appropriate site to minimise the risk when planning an apiary
- Cull bad tempered bees
- Re-queen with more docile strains
- Breed suitable strains with docile traits
- Gentle handling maintains good temper
- Inspect at optimum times, e.g. midday/afternoon in good weather when bees are foraging
- Do not inspect in bad weather
- Do not interfere with bees too often
- Minimise stresses, healthy well fed bees are happy bees
- Bees become defensive at the end of seasonal nectar flow
- If swarm been out for more than a day keep bystanders at a distance
- Avoid major disturbances to hive at times of neighbours having outside activity, e.g. BBQ.

Module 1 Honeybee Management

1.14 the year's work in the apiary and how this is dependent upon the annual colony cycle and the timing of local bee forage;

Month	Work by Beekeeper	State of Colony	Forage
January	<ul style="list-style-type: none"> Oxalic acid treatment (if Beekeeper plans to) Check for stores and feed if necessary. Check for damage to hives. Repair/replace woodwork for next season Reposition hives in apiary Check entrance free of dead bees/debris Attend Winter Association meetings/briefings 	<ul style="list-style-type: none"> In cluster Flying on warm days for toilet and water No brood Utilising stores 	<ul style="list-style-type: none"> None
February	<ul style="list-style-type: none"> Check for hive damage Check for stores and feed if necessary Repair/replace woodwork for next season Check entrance free of dead bees/debris Attend Winter Association meetings/briefings 	<ul style="list-style-type: none"> Cluster starting to break up Queen may start to lay if warm enough Utilising stores 	<ul style="list-style-type: none"> Hazel Snowdrop
March	<ul style="list-style-type: none"> Quick check of colony to see if bees present Check adequate stores present, feed if necessary Monitor varroa Remove Mouse Guards Mark and clip queens Check entrance free of dead bees/debris Give additional feed if over winter OSR in area Cleanse Hive (clean floor) if good weather 	<ul style="list-style-type: none"> Cluster broken up Queen laying Bees starting to forage for pollen and nectar Utilising stores Winter bees dying 	<ul style="list-style-type: none"> Hazel Snowdrop Crocus Salix (willow) Pears Plums
April	<ul style="list-style-type: none"> Start regular checks of brood box Full check for brood diseases Add supers Carry out comb change e.g. shook swarm, or Bailey Cleanse hive (clean Floor) 	<ul style="list-style-type: none"> Queen laying strongly if good nectar flow Colony increasing in size Drones being laid Queen cells produced 	<ul style="list-style-type: none"> Oil seed rape Cherry Ribes hawthorn Apples Dandelion Mahonia
May	<ul style="list-style-type: none"> Regular checks Swarm control Artificial swarms for increase Drone brood culling Collect swarms Add supers Honey harvest if spring crop New queen raising 	<ul style="list-style-type: none"> Queen laying strongly Colony increasing in size Drones being hatched Queen cells produced Virgin queens on mating flights 	<ul style="list-style-type: none"> Oil seed rape Cherry Ribes Horse chestnut Holly Dead nettle Apples Dandelion Mahonia Sycamore Field bean raspberry

Module 1 Honeybee Management

June	<ul style="list-style-type: none"> • Regular checks • Swarm control • Artificial swarms for increase • Drone brood culling • Monitor for varroa • Collect swarms • Add supers 	<ul style="list-style-type: none"> • Queen continues to lay, rate dependent on flow rate • May produce queen cells • Virgin queens on mating flights • Colony size at maximum 	<ul style="list-style-type: none"> • White clover • Lime • Borage • Dead nettle • Ragwort • Sunflower 	<ul style="list-style-type: none"> • Blackberry • Holly • Dandelion • Privot • Oil seed rape
July	<ul style="list-style-type: none"> • Check for queen cells • Add supers or honey harvest • Unite colonies 	<ul style="list-style-type: none"> • Queen still laying worker brood 	<ul style="list-style-type: none"> • Borage • Hebe • Blackberry • Dandelion • Heathers • Cotoneaster • Michaelmas daisies • Rosebay willow herb 	<ul style="list-style-type: none"> • White clover • Sunflower • Old mans beard • Dead nettle • Lavender • Privot • Ragwort
August	<ul style="list-style-type: none"> • Honey harvest • Return extracted supers to hives for cleaning • Full check for brood diseases • Monitor varroa • Treat with Apiguard • Replace queens as necessary • Unite colonies 	<ul style="list-style-type: none"> • Colony starting to contract • No new drone brood • Queens rate of laying slows, may stop 	<ul style="list-style-type: none"> • Red clover • Heather • Michaelmas daisies • Dead nettle • Privot • Roseabay willow herb 	<ul style="list-style-type: none"> • Blackberry • Borage • Dandelion • Lavender • Ragwort • sunflower
September	<ul style="list-style-type: none"> • Treat with Apiguard • Replace queens as necessary • Start feeding • Allow Supercedure if it occurs 	<ul style="list-style-type: none"> • Drone ejected from hive • Queen rate of laying slows 	<ul style="list-style-type: none"> • Michaelmas daisies • Ivy 	
October	<ul style="list-style-type: none"> • Feed • Put on Mouse Guards • Protect against woodpeckers • Monitor for varroa • Increase air flow • Remove queen excluder • Attend Winter Association meetings/briefings 	<ul style="list-style-type: none"> • Cluster starting to form • Bees will fly for water and toilet on warm days • Very little brood • Utilising stores 	<ul style="list-style-type: none"> • Ivy 	
November	<ul style="list-style-type: none"> • Check adequate stores by hefting • Start to prepare frames etc. for next season • Check entrance free of dead bees/debris • Attend Winter Association meetings/briefings 	<ul style="list-style-type: none"> • In cluster • Flying on warm days for water and toilet • Very little brood • Utilising stores 	<ul style="list-style-type: none"> • Ivy 	

Module 1 Honeybee Management

December	<ul style="list-style-type: none">• Check adequate stores• Check for damage• Repair/replace woodwork for next season• Oxalic acid treatment• Reposition hives in apiary• Check entrance free of dead bees/debris	<ul style="list-style-type: none">• Cluster• No brood• Flying on warm days for water and toilet• Utilising stores	<ul style="list-style-type: none">• None
----------	-----------------------------------------------------------------------------------------------------------------------------------------------------------------------------------------------------------------------------------------------------------------------------	------------------------------------------------------------------------------------------------------------------------------------------------------------	--------------------------------------------------------

Module 1 Honeybee Management

1.15 the drifting of honeybees, the dangers caused and techniques used to minimise the problem;

- How does drifting occur
 - Wind, cross wind driving bees to other hives
 - Disorientation,
 - long grass cut in front of hive
 - no key features to map
 - young bee not aware of environment
 - Colony collapse
 - Bees leaving dying colony looking for new home
 - Genetic tendency e.g. Italian Bee
 - Poor flight orientation, highly prone to drifting
 - Aggressive foragers, causing tendency to rob
 - Drone known to move between colonies
- Dangers
 - Spread of disease
 - Weakens colonies that loose significant number of bees by drifting
 - Converse recipient colony too many bees for colony
 - Conducive to robbing
 - Can cause loss of queens when flying for mating
- Techniques for prevention
 - hives should be arranged to enable the bees to find their own colony with ease
 - Entrances should be arranged pointing in different directions
 - Hives should be well spaced at least 1.2 – 1.5 m apart
 - Move hives less than three feet or more than 3 miles
 - When arranging hives do not create repeat pictures
 - Drifting at a minimum when hives arranged in a circle, colonies facing outwards
 - Ensure landmarks for bees to map
 - Distinguish the hive with paint colours or identification markers

Module 1 Honeybee Management

1.16 the principles involved in feeding honeybees, including types of feeder, amounts of food, types of food and timing of feeding;

Principles involved in feeding Honeybees

- Honeybees need to feed in order to support/stimulate certain activities
- Honey produced by the bees in summer is intended as stores for bad weather/no flow/winter
- Honey Harvested by beekeeper needs to be replaced in order for bees to survive winter
- Beekeeper can stimulate colony growth by feeding, e.g. early season build up
- Beekeeper monitors colony stores, must be minimum 10 lbs
- Feeding can be used to support bees during high energy times, e.g. Nuc drawing comb

Feeder Types

Type of Feeder	Description
Miller	Comprises a frame same size and brood/super with central slot and two dividers, enables bees to feed from one half or both. If bottom bee space need to ensure space is maintained. Bees separated from honey reservoir to prevent drowning
Ashforth	Variant of Miller with the feeder slot to one end, need to tilt the hive to ensure efficient flow of all honey
Frame Feeder	Ensures feed is closest to brood, float in honey to ensure no drowning. Requires opening brood box to refill, so really an emergency feeder
Rapid Feeder	Plastic container with riser in middle and ribbed edging, plastic cup separates honey reservoir from bees.
Contact feeder	Mesh area in lid of container, vacuum created when upturned over cover board. Bees retrieve stores through mesh. Good for Nuc. As no spillage to attract robbers etc.
Brother Adam Feeder	Similar to Rapid Feeder with the feeding area in the centre of feeder. Larger feed reservoir. Used to double as a crown board.
Atomiser Spray	If a colony is moribund through lack of stores warm solution 50% sugar sprayed onto bees, cleaning action also feeds! Also used to prevent fighting when uniting colonies

Module 1 Honeybee Management

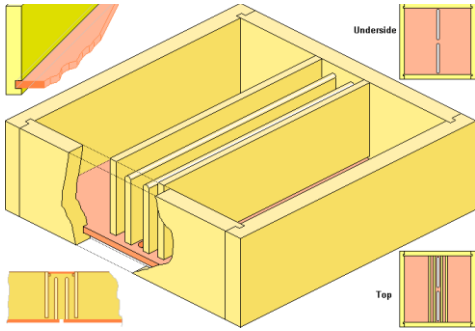

Figure 1 Miller Feeder

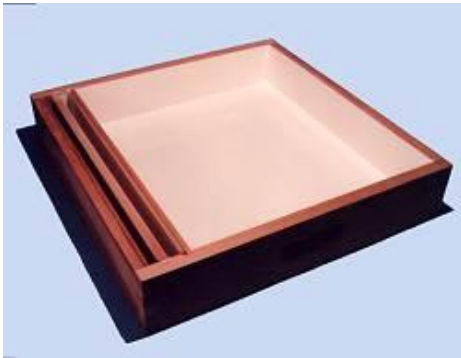

Figure 2 Ashforth Feeder



Figure 3 Frame Feeder

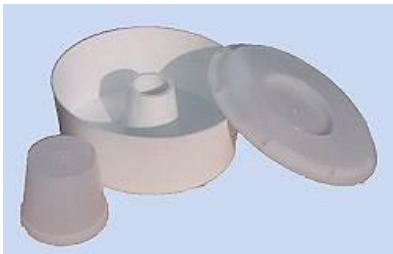

Figure 4 Rapid Feeder



Figure 5 Contact Feeder



Figure 6 Brother Adam Feeder

Module 1 Honeybee Management

Amounts of food	
Summer Stores	A colony requires 10 lb of stores to survive a week of poor weather/no flow. 1 National Brood frame equates to 5 lb and a super frame 3lb
Winter Stores	Strong Colony requires 35 lb stores for winter
Feed Calculation	Honey is 80% sugar, if 10 lb stores required 8 lb sugar required in feed
Types of Food	
Sugar Syrup	White household sugar mixed with water in either summer or winter feed concentrations
Candy/Fondant	High concentration of sugar used as winter top up
Honey	Honey from own apiary and disease free colonies, boiled to sterilise
Pollen Patties	Either substitute (soya Flour) or supplement from trapped pollen. Pollen is required in order to ensure brood rearing, vital component of brood food
Reasons for feeding a colony	
To provide adequate stores for winter	
To provide emergency stores to prevent starvation	
Means of administering drugs	
To stimulate the queen to lay	
Enhance wax production	
When colony has inadequate foraging force, e.g. as part of artificial swarm	
When raising new queens or making up a Nuclei	
Timing of Feeding	
Sugar Syrup Winter	2 kg sugar to 1 litre water, used by bees to create stores
Sugar Syrup Summer	1 kg sugar to 1 litre water, used by bees as feed, bees require 50% concentration in order to immediately digest
Pollen Patties	Early part of year to promote growth of Brood when flow is slow
Feeding colony	At dusk, whole colony at a time, prevents robbing. If a swarm feed 2 days after hiving in order to clear swarm stores held in stomachs from bees, i.e. remove disease.

Module 1 Honeybee Management

1.17 the value of honey, pollen, water and propolis to the honeybee colony;

Honey

- Bees obtain their energy from the breakdown of carbohydrate in honey and nectar.
- There are 3 major carbohydrates- sucrose, glucose and fructose.
- The bees store the concentrated nectar as honey in sealed cells, these they access for food when there is no forage available.
- Incidentally, Beeswax is also produced by the metabolism of sugars, by the fat bodies and wax glands.

Pollen

- It is the principal source of protein, fat vitamins and minerals in the honey bee diet.
- Young worker bees need large amounts to make the food fed to brood, The Queen and young drones
- The pollen is mixed with small amounts if brood food and fed to older larvae.
- It is the protein and fat content of the worker bees necessary for overwintering
- It is the building materials of the eggs and sperm
- A strong colony will collect 50-100 lbs during a season
- It requires 70-150-mgs of pollen to rear 1 adult bee
- The protein content from pollen varies from flower to flower in the same foraging area
- Because bees depends on pollen for all their stages of life, their value as pollinators is immense

Propolis

- It is the collected exudate from plants and trees
- It contains 50-55% resins and balsams and 10% essential oils
- Many of the constituents have disinfectant properties
- Bees use it to fill cracks and crevices in the hive
- Reducing entrances by building 'curtains'. This is where the word originates 'pro' means before and 'polis' means city (Greek)
- It can be mixed with beeswax to strengthen the comb
- The cells are varnished with it before the queen lays her egg. This helps to combat disease-causing organisms.
- Also used for embalming unwanted intruders that are too big to eject from the hive to prevent decay and polluting the nest.

Water

- Only a small number of bees collect water but these can be increased if the need arises
- Water is used to dilute honey stores ready for feeding, nectar is the bee's natural food and honey is concentrated nectar.
- Used to dissolve granulated sugar
- Used for manufacture of brood food by the young bees. Brood food is 70% water.
- To cool down the interior of the nest if it threatens to overheat. The water is spread on the comb, and elsewhere, and then evaporated by fanning bees.

Honey – source of carbohydrate

Sugars 82%: Major, fructose, glucose
Minor, sucrose, maltose, melezitose, trehalose

Other: Water, ascorbic acid, very minor constituents

Enzymes added by bees: invertase, diastase, glucose oxidase

Module 1 Honeybee Management

Needed for:

- Sustaining life
 - 0.7mg/hour resting
 - 10mg/hour flying
- Wax making, production of 1g wax consumes 10-12g honey
- Maintaining temperature of hive/brood
- Producing brood food
- Feeding to larvae – required for development
- Mixing with pollen for storage
- Building fat reserves for winter

A typical colony consumes 80 kg honey /year

Pollen – source of protein

Proteins 6 – 30%

Lipids 1-20% (typical 5%)

Sterols 0.5% (essential for bees)

Sugars 25-48%

Minerals 1-5%

Starch, vitamins, water, others

There are 10 amino acids from pollen essential to bees

A typical colony consumes 15-55kg pollen/year

Needed for:

- Glandular and internal structure development for young adults (0-10 days)
 - Hypopharangeal gland development (brood food)
 - Mandibular gland (brood food producer)
 - Development of wax glands
- Production of brood
- Fed to older larvae in increasing amounts (underfed = dwarf adults)
- Flying bees eat small amounts (will eat more if required to make brood food)
- Eaten to build fat for overwintering

Storage of pollen: raw pollen is treated by bees with phytocidal acid (from the hypopharangeal and mandibular glands), enzymes and honey to make bee bread which is stored in cells

Larvae feeding

Worker larvae: day 0-3 brood food, 3-5 brood food, pollen and honey

Drone larvae: eat more, drone brood food contains more diverse proteins.

Queen larvae: royal jelly exclusively

To rear one worker bee requires 100 mg honey and 135 mg pollen

Water

Water is often needed to dilute stores (remember 50:50 water honey for energy, 20:80 for storage) or to dissolve granulated shoney.

Nurse bees need a large amount of water, because brood food fed to young larvae is 70-80% water

Water is also a cooling agent when the nest risks overheating

Propolis

Module 1 Honeybee Management

Top quality, antiseptic.

Needed for:

- Fill up small cracks, keeping out draughts, rain and helps to deter wax moth
- In wild used to varnish the inside of the selected cavity
- For varnishing the inside of a cell before queen lays in it, its antiseptic quality helps to maintain healthy brood
- Build walls at front of hive to reduce entrance size both for defence and protect against bad weather
- Used in comb foundations to strengthen and cement them
- Mummify large intruders so they do not decay and pollute the nest

Module 1 Honeybee Management

1.18 the prevention, detection and control of swarming;

Prevention

- Frequent Colony inspections
- Young prolific Queen
 - Replace queen every two years
 - Maintains high pheromone levels and cohesive behaviour
- Maintain adequate space
 - Provide a brood box large enough to accommodate large colony population whilst maintain enough laying space for the queen
 - Ensure sufficient supers to:
 - Receive congestion
 - Facilitate better air circulation/ventilation
 - Provide sufficient storage space
- Good hive ventilation

Notes:

Reduce brood nest

7 frames of brood time for a super

Remove queen and remerge??

Clip queen

Detection

Signs of swarm preparation

Queen cells containing larvae and royal jelly (colony will swarm headed by old queen when cells capped at 8 days)

Younger wax building bees "hang up" in clusters between frames

Bees crisscrossing the frame banging into each other

Situations leading up to swarming

When population increases may-june causing overcrowding

Old queen

Queen not laying

Control

Artificial swarm when queen cells detected

Tear down/remove queen cells

Make more space

Requeen if old queen

Merge with colony with young queen

Module 1 Honeybee Management

1.19 the use, and types, of queen excluder used in the United Kingdom;

A queen Excluder is a grid of slotted zinc, wire or plastic where the spaces are too small for a laying queen to pass through. Drones are too big to pass through a queen excluder.

Workers sometimes are reluctant to go through the Queen Excluder from the Brood Box to the Super, if this is the case provide drawn comb or foundation in the super or leave the Queen Excluder off until the bees start to draw comb, replacing the Queen Excluder after ensuring the Queen is in the brood box.

Use

- Placed between brood box and super to prevent the queen accessing areas of the hive the beekeeper does not want brood.
- Placed on top of newspaper when uniting two colonies to prevent the paper blowing away
- Placed beneath the brood box after a shook swarm to prevent the queen absconding. Remove after 1-7 days as Drones cannot get through and pollen tends to be knocked off by the excluder.
- Under the hive when sieving colony to find the queen using a swarming board. Alternatively place between super with drawn foundation and brood box. Only use when you need to find the queen in order to cull her, very traumatic process.
- As part of the Bailey comb change to isolate queen in top brood box

Types

- Wired framed with frame on one side only so that bee space can be maintained either top or bottom.
- Slotted zinc or galvanised steel can be frameless but not easy to work, can stick to tops of frames (bbs) or sags in middle (tbs) either way will be propolised
- Zinc or Steel framed
- Plastic slotted without a frame, wax can be removed when it is cold and brittle, price main factor for choice
- Waldron frame has wires in middle of surrounding frame so bee space is never right!
- Herzog, round wires on frame with bee space frame
- Welded round wire

Module 1 Honeybee Management

1.20 methods of swarm control used in small-scale beekeeping enterprises;

Clip the queens wings, when the colony swarms the queen cannot fly, the swarm returns to the hive and adopts the new queen.

The Artificial swarm

If you find unsealed queen cells in the hive during a routine inspection but no sealed queen cells it is a sign they are preparing to swarm. The good way to deal with this is to do an artificial swarm. This splits the colony into two and persuades the bees that they have already swarmed but you do not lose any bees in the process.

You will need a second brood box, another roof, floor and hive stand. It is a good idea to have these ready at the beginning of May because the artificial swarm should be carried out on the same day that you find the queen cells – the following day may be too late.

Fill the new brood box with a complete set of frames with new foundation. The steps to carry out are shown in the following illustration.

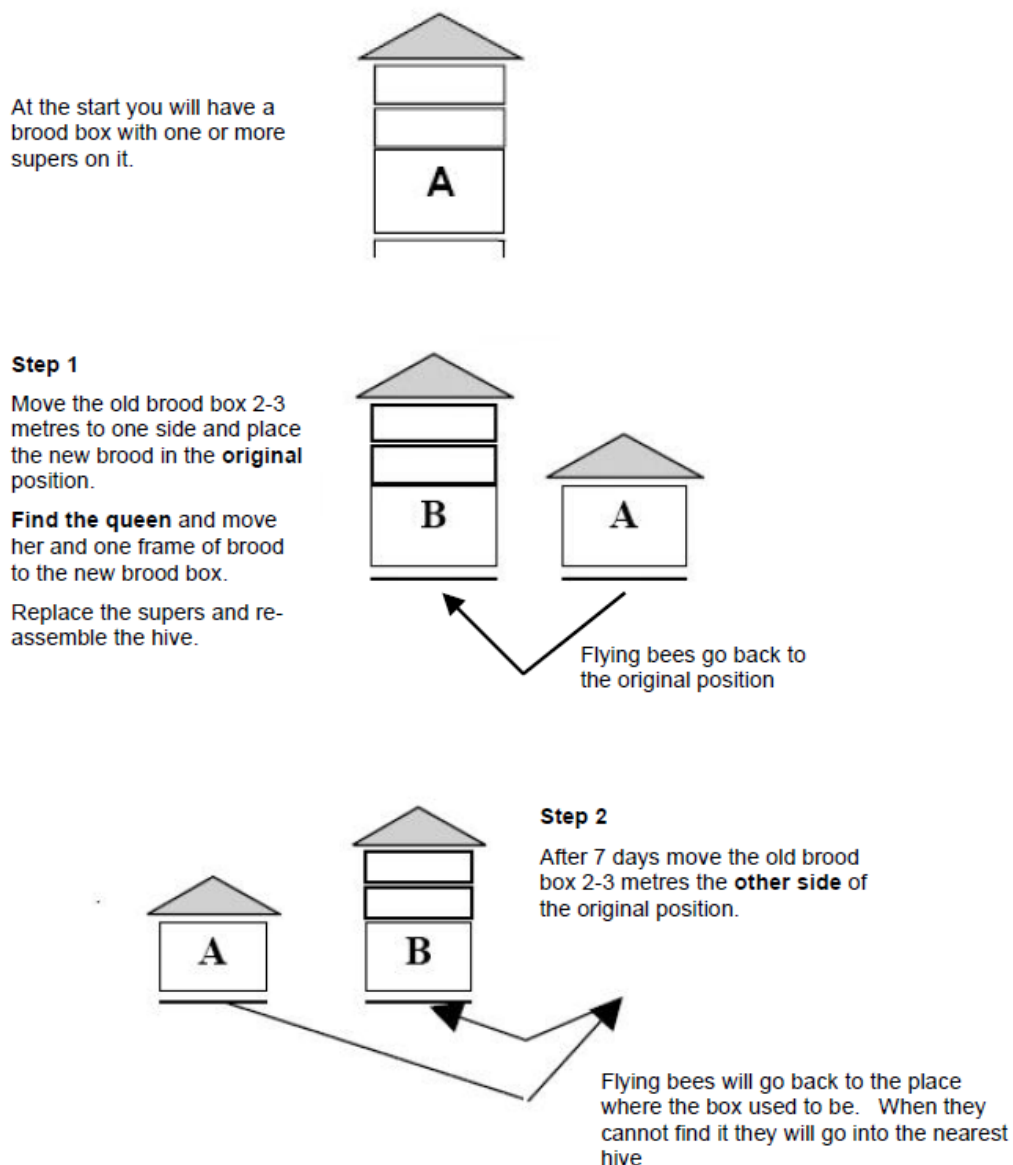

Module 1 Honeybee Management

Important notes:

1. The artificial swarm can only be done if the bees have not already swarmed. You must do it before the queen cells are sealed.
2. After you have moved the old brood box to one side (step 1) you should go through it and remove most of the queen cells. Only one or two cells should be left and these should be selected as the ones that are unsealed and contain the fattest, healthiest looking larvae.
3. Make sure there are no queen cells on the frame with queen on which is moved to the new box.
4. After 4-5 days check again for queen cells
5. The new queen(s) will emerge 16 days after the eggs were laid. It normally takes about 2 weeks for the new queen to mate and start laying but it can take a bit longer. Eggs and young larvae should be present no later than four weeks after the queen has emerged.
6. When the new queen has started laying, the two colonies can be united if you do not want to increase the number of colonies you maintain. Remove the old queen from colony B so that your combined colony has the youngest queen.

Demaree Method

Locate a spare brood box with foundation or drawn comb. This spare box minus its centre comb was placed on the original floorboard.

Run through the original box and find the queen, take her and the frame she was found on and place it in the centre of the new box, removing any queen cells that are on that frame, as you do so.

Put the queen excluder on this new box and then the supers (add another super if thought prudent at the time). Place an additional queen excluder over the supers.

Returning to the original box, move the combs to one side of the box and fill the empty space at one side with the odd drawn comb that was removed to make the gap. This box now goes on top of the topmost queen excluder.

Fit crownboard and roof and the job is done.

This will prevent swarming for 14-21 days

Horsley Board

When a colony is found to be producing Queen Cells... and the queen can be found.

- a) Move the entire colony one hive space to left or right, place the new stand and floor where the original one was.
- b) Put the new brood box on this new floor with the frames of comb in the centre and any foundations towards the outside. Remove the central frame thus creating a space.
- c) Find the queen and place her, and the frame she is found on, into the space in the middle of the new brood box, removing any queen cells that are found on this frame.
- d) The queen excluder, and the supers are then placed on the new box.
- e) The Horsley Board goes on next, with its entrance wedge on the upper side and to the opposite face of the hive to the main entrance. It should be in the closed position allowing traffic through its small panel of queen excluder.
- f) On the Horsley board sits the original brood box, containing its frames complete with their queen cells, and the empty frame that was pulled from the new brood box is added to the outside to make good the space created when the queen was found.
- g) finally the crown board and roof are positioned, leaving the original stand and floor to be carried back to the car.

Module 1 Honeybee Management

After 3 to 4 days open the entrance wedge on the Horsley board which isolates the bees in the top box from the queen and those below the Board. Older bees will leave by the new entrance, but return to the "main entrance". This reduces the number of bees in the top box and should ensure that no swarm will issue when the first new queen emerges.

Do not disturb for four weeks after which time there should be a newly mated queen laying in the top box. This "new" queen can be used for increase or to replace the old queen by uniting.

If increase is desired... As soon as the new queen is proven to lay then she can be removed, along with a frame of sealed brood and a frame of open brood, from the bottom box to form a nuc that can be housed elsewhere. Then the whole procedure can be repeated with a subsequent trade off of slightly lower honey surplus.

Snelgrove Board

Snelgrove's ingenious swarm control method is suitable for the beekeeper with a few hives in the garden. It relies on splitting the colony and continuously bleeding young bees from a top brood box to the lower part of the hive. Many variations in use are possible - his first method is as follows:- Reorganise the hive with the queen on one frame of open brood, with other broodless frame, at the bottom, then a queen excluder, supers and finally another box with all the other brood frames. Four days later, put the Snelgrove board under the top box and manipulate the entrances in sequence.

Day 4: Open top left entrance.

Day 7: Close top left, open bottom left and top right.

Day 14: Close bottom left and top right, open bottom right and top back.

Queen cells in the top boxes should be destroyed and the two brood boxes later united.

Module 1 Honeybee Management

1.21 methods of marking and clipping queens

First Catch the Queen!

- Hold the frame with the queen on frame surface in the cradle of your left arm (assuming you are right handed)
- Guide the queen by placing a finger close to the eye, just like sailing a boat, left eye by finger makes the queen turn right.
- The frame should be angled so that the queen runs up the frame
- With the right had approach the queen from behind and clasp her wings between the forefinger and thumb

Second Mark and Clip her

The following steps are taken from the Dave Cushman website, <http://www.dave-cushman.net/bee/clipmark.html>

Step by step (assuming right handed)

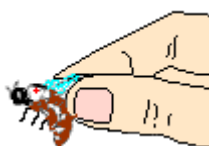

Using your right hand, pick the queen off the comb using thumb and forefinger to grip both pairs of her wings... as shown left.

Then point the forefinger of your left hand at your right shoulder, keeping your hand up towards your face at a comfortable distance for good vision. (Illustrated at right.)

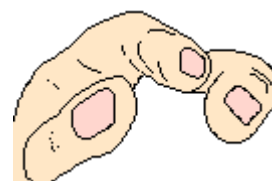

Offer the queen towards the tip of your left index finger and she will grip it with all six legs. Now gently close the tip of the left thumb and the side of the second finger onto the queens legs. You may now release the grip of your right hand (left picture).

Dab on your marking paint or glue your numbered identification disc in place.

Then while the paint dries... do the clipping operation.

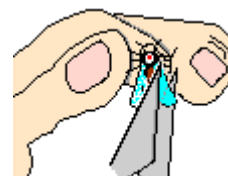

Aim your left hand at an angle as if to miss your right shoulder then slightly lift the queen's right wing with the tip of the lower blade of the snipper, position the blade so that about one third of the wing will be amputated. After ensuring that there is no spare leg involved and that the blades are perpendicular to the wing surface... complete the cut. Do the marking first particularly if using fish glue, to attach numbered discs, which requires a slightly longer drying time than paint.

Module 1 Honeybee Management

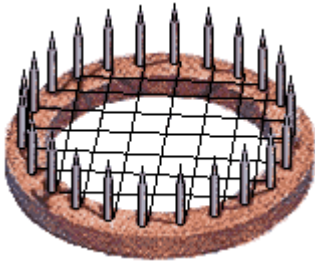

This gadget is known as a Baldock cage, it is simple to use and will not harm the queen providing that it is not pressed too heavily into the comb. When it is not in use, press it into a piece of expanded polystyrene foam (styrofoam) which will protect your hands from the sharp points and the prongs themselves from damage.

This method of marking is employed when an unmarked queen is in a full sized colony.

It is used with the prongs on the surface of capped brood, unfortunately a few pupae may be damaged by the prongs, but this is a small price to pay for a simple method.

The spacing between the prongs is large enough to allow workers to escape, but the queen has a larger thorax and thus is captive. She is immobilized by pressing the cage down until she is gripped by the soft and compliant mesh. When she is still it is an easy matter to dab on paint or cement a numbered disc to her. A few moments delay to allow the paint or cement to dry and the cage is withdrawn.

There is a colour scheme in use for marking honey bee queens...

Colour	Year
White	1 and 6
Yellow	2 and 7
Red	3 and 8
Green	4 and 9
Blue	5 and 0

Will You Raise Good Bees

There are also coloured discs and numbered discs with coloured backgrounds. Grey is occasionally used instead of white. I have used quick drying silver paint sometimes, as this is very 'visible'.

The discs are small and difficult to handle with clumsy fingers... A way to have them ready for the instant that you require them, is to put one end of a piece of thin tubing in your mouth place the end of the tube on the top surface of the disc then apply suction with your mouth. The disc will stay in position and can be allowed to dangle ready to be applied when you have dotted the adhesive on the queen.

Module 1 Honeybee Management

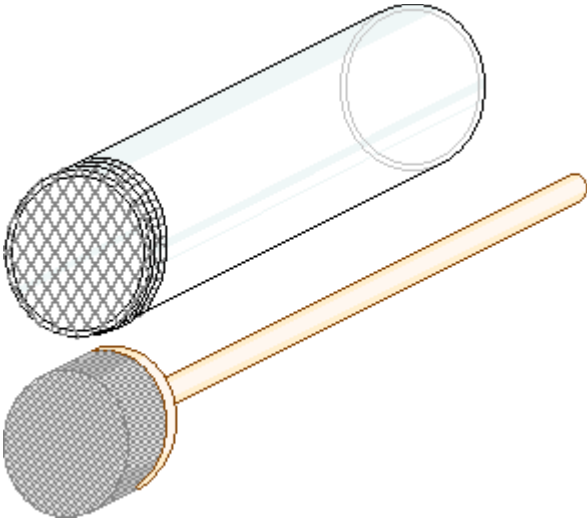

The tube cage, this is better when using the glue and numbered discs, as you can take the queen away from the hive and buzzing bees to mark her, with this cage you can also clip one wing at the same time. The cage consists of a 30 mm glass (or plastic) tube about 80 mm long with a 5 mm sq. elastic mesh stretched over one end and held in place with a rubber band, a 28 mm plunger covered on the top with a 9 mm thickness of soft plastic foam. To use it the queen is captured in the open end of the tube and the plunger inserted into the mouth of the tube, to hold her captive. Cover the brood box to keep the bees happy while you take the queen away to mark her, prepare the glue and disc then push the plunger up to trap the queen against the mesh with the dome of her thorax through a mesh hole to mark her. If you also wish to clip a wing, you can twist the plunger slightly and one wing tip will poke through the mesh, cut off about 4 mm and the job is done. Withdraw the plunger about 25 mm the queen will walk about un-harmed wait a few minutes to let the glue or paint dry, pull the cover off the brood box place the tube along a seam between the frames, pull the plunger out, and let the queen walk out and down on to the comb.



Karl Jenter manufactures this plastic device that resembles a clothes peg, they call it 'queen pliers', which sound a little less brutal. This has soft sponge areas for gripping the queen's abdomen and small, stubby, transverse silicone rubber tubes that grip the sides of the queen's thorax. It is spring loaded and the 'grip limit' can be set using the thumbscrew.



1.22 the methods of making nuclei and the uses to which nuclei can be put;

Preparation

Choose the parent colony with care. Avoid breeding a new queen from a strain of bee with undesirable characteristics.

Module 1 Honeybee Management

Equipment required:-

- Nucleus Box,
- 4 Replacement frames with drawn comb or foundation,
- a means of isolating the queen.

Principles

- Nucleus should comprise at least 4 Brood frames
 - 2 x stores
 - To feed the Nucleus
 - 1 x sealed or mainly sealed brood
 - To supplement the bees within the Nucleus
 - 1 x Unsealed brood in order of preference
 - With new mated Queen (introduce after flying bees have left)
 - With uncapped Queen cell
 - With capped Queen cell
 - With eggs less than 3 days old
- Source of Frames
 - Preferably from several colonies , ideally 1 frame from each of 4 colonies and bees from 5th
 - Strong single colony
 - Artificial Swarm
- Bees within the Nucleus
 - Must employ non-flying bees
 - Must have sufficient number of bees
- Feed the Nucleus
 - Only start feeding after flying bees have left
 - Increases chances of Nucleus being left alone
 - Amount of feed will be dependent upon weather

Uses

- A nucleus colony can be used to prevent overcrowding in a larger, healthy colony by splitting some of the population off to a new colony
- A nucleus can also be used to care for spare queens (sometimes called breeder colony)
- A nucleus colony can be combined with the larger colony to re-queen it with a much smaller break in brood rearing
- A nucleus can also grow into a full sized colony
- Supplement a colony
- Observation Hive

Method 1

- Remove supers and queen excluder.
- Find the queen and isolate her to ensure that she does not find her way into the nucleus box.
- Select two frames of stores, mainly honey, and place one on each side of the nucleus box, together with adhering bees. This will provide sustenance for the nucleus, which will be denuded of flying bees for a couple of days.
- Select one frame of mainly sealed brood. This brood will soon emerge and reinforce the young bee population. It is young bees that will produce an abundance of royal jelly to ensure that our new queen larvae are well provisioned. This frame is placed, with adhering bees, between the two frames of stores.
- Select one frame containing eggs, or larvae less than three days old. This is the frame from which the new queen will be produced, and should be placed by the side of the frame of sealed brood, together with adhering bees.
- Take two further brood frames, and after letting the flying bees return shake the bees from them into

Module 1 Honeybee Management

the nucleus box. Remember that all the flying bees will return to the parent colony, and these extra non-flying bees will be required to reinforce the nucleus.

- Close the nucleus frames up together, to establish correct bee space, and insert a dummy board if necessary. Put on crown board and roof, and move to its permanent position, making sure that the entrance is open about half an inch.
- Return to the parent colony. Reintroduce the queen and push remaining brood frames up together to form a contracted brood nest. Replace frames taken with drawn comb or foundation. Replace queen excluder and supers, and close hive.
- Go back after 3 days and remove all queen cells to ensure only one day old Larvae are employed in queen cells

Notes:-

- When all the flying bees have returned to the parent colony, the nucleus may be fed.
- If the parent colony already has queen cells, then it would be beneficial to utilise one of these in the nucleus, breaking down those remaining.
- It may be preferred, to introduce a new mated queen, rather than wait to breed one's own. If so, this is best done in the evening, after the new nucleus has settled down, and all the flying bees have returned to the parent colony. The new caged queen can then be quietly wedged between the two centre top bars, and the nucleus left alone for a period of five days. The nucleus will also required drawn comb o allow the new queen to lay eggs within
- There may be odd occasions when it would be beneficial to take the stores, bees and sealed brood from a particularly strong hive, and the frame of eggs from another colony with better characteristics. In this instance it must be remembered that all the bees should be shaken from the "egg" frame, (it is not a good idea to mix bees from different colonies), and also, in seven days, the nucleus should be checked to ensure that there are no queen cells other than those on the desired frame. If so, they should be broken down.
- To ensure you get young worker bees for the Nucleus shake bees from frames with unsealed frames, sometimes best to shake into bucket and then add to Nucleus, again allowing flying bees to return. Best method to remove flying bees from comb is stand away from hive with frame and flying bees will leave the frame

Method 2

- If finding and isolating the queen is a problem, then use this method. It is more time consuming, but avoids the necessity to find the queen.
- Select your four frames in the same way as method one, but shake any adhering bees back into the hive, which will ensure that the queen is not on either of these frames.
- Place the frames in an empty brood chamber, and put to one side.
- Push the remaining brood frames up together, and add replacement frames.
- Replace queen excluder and supers, but before replacing the crown board, put on the brood chamber with the four selected frames, then the crown board and roof.
- Leave like this until the evening, or two to three hours. During this time the bees will find the brood in the upper brood chamber, and young bees will come up from the lower chamber to cover and feed it.
- This now becomes your nucleus, and can be removed and re-sited.

Method 3 (Artificial Swarm)

- The first stage of the artificial swarm is done as per normal, i.e.
 - a new box with fresh foundation is placed at the original position
 - the queen is moved into this
 - the supers replaced and the old brood box moved away
- Split the old brood fames into two sets making sure that each set contains at least one frame with queen cells on it
 - In practical terms, one set stays in the original brood box with dummy boards at each end and the other set is transferred to a nucleus box
 - Notes
 - effectively this has made up two nuclei from the one colony and two new queens will be produced

Module 1 Honeybee Management

- you must have a strong colony to start with otherwise the nuclei will be short of bees
- be prepared to feed the nuclei if the weather is poor
- one advantage is that it is far less likely that the bees will make a secondary swarm when the first of the queens emerge. Bees are far more reluctant to produce a cast from a nucleus of 5 frames than they are from a full colony.

Module 1 Honeybee Management

1.23 how swarms and nuclei can be turned into productive colonies;

Primary Swarm consists of:

Laying queen
Foraging bees
House bees
Scout bees

But has no drawn comb nor honey/pollen stores except that carried by bees (up to 4 days stores)

Need to provide:

Home, hive nuc or full size dependent upon swarm size
Frames of foundation (as you want the bees to use up all the honey they brought with them to make wax)
Food after 24/48 hours, spring feed 1:1 via contact or rapid feeder
Site in a good forage area (away from other colonies if possible, due to disease risk)

Then check:

The queen is laying
Monitor for disease, particularly varroa and treat appropriately
Provide supers as colony increases in size when queen laying strongly and bees need additional space
As history of queen is unknown consider the following options

Re-queen in the autumn

Unite with other colony

These are dependent upon observations of temperament, build up and disease of the swarm

Cast

Will have a virgin queen so may not see any brood for up to 4 weeks, proceed as above but do not disturb for 1st week, to prevent disrupting mating flights.

Nucleus consists of:

Laying queen
Nuc box with frames of brood and stores
Foraging bees
House bees

Then

Check to ensure queen is laying
Feed by frame feeder or contact feeder if necessary
Monitor for and treat varroa as necessary
As frames fill add new ones until nuc box is full
Transfer to full size hive, add more frames outside the brood nest, feed if necessary
Spread brood across drawn comb frames to encourage quicker build up
Add supers as necessary

Module 1 Honeybee Management

1.24 methods of taking and hiving a swarm of honeybees;

Pre-collection

Before attending:

- find out the nature of the swarm
 - are they honey bees, bumble bees, wasps or solitary bees
- where is it situated
 - tree, bush, post wall etc.
- public or private land
- access
- location close to footpath, public open space, school?
- How big is it?
- How long has it been there

Things to take along:

- Protective clothing (suit, gloves and boots)
- Container to catch the swarm
- Large white cloth to spread on the ground
- String
- Scissors
- Secateurs
- Smoker
- Fuel
- Matches
- Step ladder
- Mobile phone

On site

- If private land, get owners permission
- Describe to land owner what you intend to do
- Ask that all onlookers are kept away, preferably indoors with windows shut
- If footpath close by, station helpers away from the swarm to prevent passers by
- Light smoker and spread sheet on ground below the swarm

Taking the swarm options:

Hanging from a branch of a bush or a tree within easy reach of the ground or a stepladder

- Place container below the swarm
- Grab branch and shake firmly so the cluster falls into the container

High from the branch of a tree out of reach

- Requires the use of a bag attached to the end of a pole
- Place bag over the swarm and jerk firmly upwards so that the cluster is dislodged into the bag

On a post or wall with access above it

- Invert the container above the swarm
- Gently brush the bees upwards to start them moving into the container
- Smoke gently from below to drive the bees upwards into the container

Other positions

- Place container as close as possible to the swarm
- Brush the bees into the container
- Use smoke to prevent them crawling out of the container

Poor access

- Employ frame of brood to entice swarm

Post collection on site:

Module 1 Honeybee Management

- Invert the container over the sheet and prop up one side approximately 1 inch
- If the swarm location is within reach smoke thoroughly to drive returning bees away and to neutralise the smell of the cluster
- If weather is hot take measures to prevent overheating of the swarm in the container (shade)
- Leave at least 2 hours or until early evening to allow flying bees to return to container
- Remove the stick propping up one side of container, gather sheet over it and tie down securely
- Transport the swarm to the apiary

At the Apiary

- If practical, the swarm should be kept as far away as possible from other colonies until assessed for disease
- Release the string and place the container upside down close to the position of the new hive
- Place stick under one side to provide ventilation
- Prepare hive/nucleus box with frames of new foundation

Hiving the swarm

1. Place a board in front of the hive, sloping up to the entrance, the lower end on the cloth beneath the container. Tip the bees out of the container onto the sheet and the bees will walk up the board into the new hive
2. Place a second, empty brood box on top of the one containing the frames, tip the bees from the container directly into the hive. Put the roof on immediately. The following day remove the empty box, brushing any bees down into the bottom box.

After care

- Feed with sugar syrup (1:1) after 48 hours using rapid or contact feeder
- Repeat if weather is poor or nectar flow is weak
- Examine after three weeks for:
 - Laying queen
 - Good brood pattern
 - No brood diseases
 - Temper

Re-queen or unite with another colony later in season if necessary.

Module 1 Honeybee Management

1.25 the methods used to unite colonies of honeybees, the underlying principles of these methods and any precautions that should be taken;

Reasons for uniting a colony:

- In autumn – if colonies are too small and weak to survive through to next spring
- In Spring – if colony comes through winter Queenless or queen is laying drones
- Swarms – A beekeeper has taken more than one swarm with lack of hardware or taken two weak swarms
- Queenless – a colony may go queenless mid season and there are no other queens available, and no sign of emergency queen cells

Basic principles

- Allow bees to mix slowly
- Disorientate the two colonies to be united
- Confuse the bees scents so they all smell the same
- Use a degradable barrier
- Prior to uniting colonies should be placed within 3 feet of one and other to preserve both sets of flying bees

Paper method

- Check for disease/queen cells before doing anything, know why the colony is weak
- Find and kill the poorer queen (if there are two), leave the queenless colony to settle
- In evening open the queenright colony very quietly, remove crown board
- Place newspaper sheet on top of frames, hold in place with queen excluder
- Make holes in paper to enable scents to mingle
- Place queenless colony on top of queen excluder
- Leave for 6 days
- At next inspection clear newspaper
- Remove the supers from lower colony to top of united colony
- Redistribute frames in colony or queened brood

Direct (dusting) method

If the 2 colonies are full size, say 2 Nucs, may be possible to unite directly

- Check for signs of disease/queen cells before doing anything
- Place both colonies together and leave to settle
- If both colonies have queens, choose the one to keep
- Relocate the queenright colony first
- One frame at a timelift the colony out of it's box, spray or dust the bees with something that will mask their scents. Flour, icing sugar or scented water are suitable
- Do same to queenless colony

Swarms

Swarms may be united directly

Queens left to sort themselves out by natural selection

Swarms hived for up to a week can accept others by direct method

Module 1 Honeybee Management

Newspaper bag method

If uniting 1-2 frames into colony

Put frames into paper bag with holes to allow scents to mingle and bees will work themselves out of the bag

Module 1 Honeybee Management

1.26 robbing by honeybees and wasps and the associated dangers, including prevention and curtailment;

If scout bees from a colony discover an easy source of honey or syrup they will incite robbing of that source, if that source is another weaker colony it is a danger to that colony as it will eventually be starved of stores. Robbing is most likely to occur at the end of the main flow when bees are still stimulated to search out food sources or during flow gap when colonies are starving.

In the same way in late summer when the wasps leave their nest in the late summer they are on the lookout for sugar sources.

Not only is the loss of stores a danger to a colony, the fighting to defend the colony saps the colony and in the case of wasps results in the death of many bees.

Recognition of robbing:

- No direct flight into the colony, robbers zig zag on approach
- Reaction of guard bees challenging newly arrived worker
- May "attack" pull at foreigner until they are removed from the hive or killed
- Chewed wax cappings under the hive if mesh floor or on solid floor
- Robbers leg position on leaving colony will show them full of honey, rather than on arriving

Prevention of robbing includes:

- Opening hives for the minimum of time, always cover supers if they are removed before examining the brood chamber
- When feeding, do it in the evening when there is likely to be scout bees about
- Feed colonies in the apiary at the same time, it is said if you open all the hives at the same time this causes confusion and permits the beekeeper to feed the bees without inciting robbing
- If you have a weak colony or nuc reduce the size of the entrance to aid guarding by the colony
- Do not leave supers or frames out for cleaning
- If feed is spilt douse with water
- Leaky feeders
- Feed nucs with contact feeder or frame feeder if possible
- Return wet supers in the evening
- Maintain equipment to be bee tight

To curtail robbing:

- If robbing by wasps, put out wasp traps to catch and kill wasps
 - Seek and destroy wasps nest
- Reduce the entrance size
 - Close any holes/gaps with foam
 - Entrance temporarily blocked with grass
 - Open mesh floor closed off to reduce smells
- Employ a tunnel as the entrance again aiding the colony guards
- If possible move the colony away from the apiary (3 miles away), leave a frame or some honey so robbers think they are finished with source (dried up)
- If a hive is robbed out leave it there as if you move it within the apiary the robbers will search it out and may attack another hive
- Put board/piece of glass in front of entrance, bees from colony ok on exit, robbers confused in finding entrance

Module 1 Honeybee Management

1.27 spring management of honeybee colonies;

Spring Management

Resist the temptation to open up hives until a really suitable day arrives (>14°C/57°F) to avoid chilling brood – *short sleeved shirt* weather. When bees are foraging on *Ribes sanguineum*, the flowering currant, it is safe to carry out a detailed inspection. Until then, spend some time observing the level of activity at entrances and note variations (see *At the Hive Entrance* by H. Storch). On a warm day, bees will make *cleansing flights* (keep quiet about the yellow streaks on your neighbour's washing!). Early flowers will provide pollen – if you see pollen being taken into the hive, the bees are alive (!) and the queen is probably laying.

Spring forage:

January/March. Winter aconite. *Eranthis hyemalis*. PN.

February/March. Snowdrop. *Galanthus nivalis*. P.

Crocus. *Crocus* spp. P.

Gorse. *Ulex europaeus*. P.

Hazel. *Corylus avellana*. P.

Willow. *Salix caprea* (goat).

P. *Salix egyptica*. P.

Yew. *Taxus baccata*. P.

If one colony is active and another one is not, a **quick** inspection may be necessary. If the colony has died, remove or seal to prevent robbing – ascertain the cause of death (starvation/disease). *Heft* hives. One way is to use a spring balance and lift opposite sides of the hive from under the floor, noting the weight on each side. Add the two together and this gives an approximation of the hive weight. Do this at the start of the winter and then every month and record the weight loss. An average colony will consume about 2 kg of stores per month during this period, depending on the weather.

If short of food, feed syrup (1 kg sugar/1 litre water) in a contact feeder or fondant/candy/icing sugar in the evening (emergency feeding straightaway) – more colonies die in April from starvation than during the winter. Minimum reserve in April is about 10 lb (2 BS full deep frames). Provide a source of water to avoid conflict with neighbours – 150g needed daily to dilute stores to 50% solution, which can be metabolised, 1 kg/day needed in the summer for cooling.

The early flowering of oil-seed rape, which has increased so greatly in acreage, has made early management of colonies in spring very important, compared with earlier years. Colonies need to be strong and healthy by early April.

England had 540,000 hectares Oil Seed Rape in 2016.

1 hectare = 100 kg honey. 1/3 rd of potential = 13, 000 tonnes honey.

UK honey production = 1,000 – 3,000 tonnes.

It has been shown that the stimulative feeding of syrup in the spring has little or no effect upon established colonies – more effect can be obtained by feeding pollen supplements or substitutes from about the second week of February. This stimulates the queen (which should laying by this time) to continue to lay and to increase the brood area, resulting in a considerably larger adult population by the time the rape is in flower.

A *pollen substitute* is any material that can be fed to colonies to replace its need for pollen. A *pollen supplement* is a pollen substitute that contains about 10% (dry weight) pollen (pollen can transmit AFB, EFB and chalkbrood). Pollen traps can be used during the summer to harvest pollen – store in fridge/deep freezer.

Pollen Substitute

Toasted soya flour 1 part by weight.

Dry brewer's or baker's yeast 1 part by weight.

Dissolve 2 lb sugar in 1 pint water. Add sufficient sugar syrup to dry ingredients to make a stiff dough. Place the patty over the combs where the bees are clustered. Cover the surface with waxed paper to prevent

Module 1 Honeybee Management

drying.

A **pollen supplement** can be made by adding 1 part pollen.

The above & more formulae can be found in The Illustrated Encyclopedia edited by Roger Morse & Ted Hooper ISBN 0 7137 1624 X.

First inspection: ambient temperature c. 14°/60°F

- Have a good reason for opening hive - plan.
- Have everything to hand.
- Be as quick as possible.
- Use cover cloths.
- By early March, depending on the weather, colonies should start to expand with increasing amounts of brood and increasing demands on food reserves. When the temperature is <14°C, a **quick** preliminary check can be made. Remove the roof & look through the holes in the crownboard. Note smell coming from inside the hive. If it smells yeasty/musty check whether the colony has died. A torch is useful to illuminate the frames. A colony that has died from starvation will have workers with their heads deep in cells trying to access the last of the stores. Are the bees at the top of the frames (i.e. stores consumed)? Bees can starve even when surrounded by stores - *isolation starvation* occurs when it is too cold for the bees to move to food. Larvae may be thrown out of the hive, but may go unnoticed – birds enjoy these tasty morsels! Close hive entrances of dead colonies & remove asap to avoid robbing. Remember, it takes 3 weeks from egg to adult worker. Small colonies will build up on OSR, but will not produce a surplus honey crop.
- When the temperature is >14°C, you can carry out a full inspection.
- Inspect area in front of hive – are there dead or crawling bees? Are there signs of dysentery (brown streaks on outside of hive)? Clear area around hive – check hive stands. Remove mouse guards.
- Lower crown board, if raised. Scrape top bars/queen excluder. Clean or replace floor (note damp patches). **Put all scrapings into a container.** Move damaged/old frames to be removed to outside – avoid splitting the brood nest*.
- Is the queen present or is there evidence of her presence (eggs/larvae/sealed brood)? Check sealed brood – flat (worker) or domed (drone). If all the sealed brood is domed and in a regular pattern, suspect a drone laying queen. If the brood pattern is irregular with domed worker cells and cells containing several eggs on the walls, suspect a laying worker. Test by inserting a frame of eggs/larvae from another colony. If no queen cells are raised, a queen is probably present. If queen cells are raised, the colony is queenless. Since there will be no drones for mating, the colony should be united to a queenright colony using the newspaper method. Alternatively, move the hive approximately 200 yards (180 metres) and shake the bees on the ground, allowing them to find their way into other colonies – if laying workers are present, it is advisable to cage the queen for 2-3 days to prevent the laying workers killing her. The colony to be united should be free of disease.
- Does the brood look healthy?
- Are there sufficient stores (honey & pollen)? Feed syrup in a contact feeder if less than 10 lb (2 BS deep frames).
- Unite weak colonies (disease-free). Swap weak with strong colonies (pollen coming in). Split strong colonies. Equalise colonies.
- Mark/clip the queen – easier when the colony is still small.
- Assess varroa level – put floor debris in methylated spirits to float mites. Treat if necessary.
- Check for disease -foulbrood and Nosema
- Prepare supers & frames – super by about mid-March.
- Record.

**Spreading brood, recommended by some authors, is the best way of chilling brood: If the beginner is in any doubt he should avoid this practice & the risk it entails – Teach Yourself Beekeeping by A.N. Schofield.*

Evaluation:

- Has the colony sufficient room? Do you have supers/frames ready?
- Is the queen present and laying well? Is drone brood present?

Module 1 Honeybee Management

- Is the colony building up as fast as other colonies in the apiary?
- Are there signs of disease or abnormality?
- Are there sufficient stores until the next inspection?
- Are queen cells present?

Module 1 Honeybee Management

1.28 management of honeybee colonies for honey production from oil seed rape and other specialist crops such as heather;

There are several forage crops which offer high nectar levels and upon which the honey bees produce large honey stocks.

The principles for all specialist crops (including oil seed rape, heather and field bean) are the same.

The beekeeper should build up the colony prior to the crop coming into flower

Oil Seed Rape can flower in April through July so as part of the spring management the beekeeper should ensure strong brood expansion by feeding syrup and pollen as necessary

For Heather the build up needs to be in July for August harvest

The colony needs to have a strong queen

During the flow

For Oil Seed Rape the bee will fly up to 2 miles for the nectar

The colony can be moved to a suitable site close to the crop

Due to the special nature of the honey produced the hive should have fresh supers for the flow

Oil seed rape crystallises on the comb and very quickly at the end of the flow

Heather is Thixotropic and lends itself to cut comb and section honey

After the flow

As the colony will have built up to a strong state care should be taken to ensure there is sufficient forage, stores or feed available to maintain the colony. If there is a lack of forage the beekeeper can return the original supers with uncapped honey or feed medium syrup.

Module 1 Honeybee Management

1.29 summer management of honeybee colonies;

Summer build up starts from the end of April and continues to the end of August. It ends with the removal of the main honey crop. The objectives during the summer are to encourage the colony to increase in size without swarming and to build up stores of honey for the bees and the beekeeper. This is the time when the beekeeper will create any new colonies and new queens for the next season.

Inspect weekly for signs that the bees are preparing to swarm. If the queen is clipped the inspections can be done fortnightly. If the bees are preparing to swarm then appropriate control measures must be taken.

Ensure there is enough space for the brood nest to expand and put on plenty of supers to give the bees enough room to process nectar into honey.

Once the swarming season is over (July), there is no need to have lots of supers. This is the time to add supers only when the existing ones are nearly full and are capped.

In August the flow of nectar will reduce greatly. This is time that bees will try to find sugar from anywhere they can. Given the chance, they will invade another colony and rob its stores. If a colony is strong it will be able to defend itself but a weak colony may be overwhelmed. At this time of year the colony can also be attacked by wasps.

The hive entrance should be closed to a very small gap which will allow the colony's own bees to come and go but will make it easier for them to defend against intruders.

Be particularly careful when any hive is open and also remove supers from the apiary as soon as they are taken off the hive for processing.

When removing the supers you must decide whether you want to take off the maximum amount of honey or whether you are prepared to leave some of it behind for the bees to use during the winter. If you take it all you will need to feed sugar to make up their stores (see following section).

In August a detailed inspection should be carried out to look for signs of disease. The bees should be shaken off each frame into the hive and the frames examined for brood diseases.

Wet supers (i.e. ones with some honey on them after the bulk has been extracted) should be returned to the hive from which they were taken, to be cleaned up by the bees.

Module 1 Honeybee Management

1.30 moving colonies and the difficulties and dangers involved;

There are many reasons for moving bees and any number of ways it can be done. However, everyone who has ever moved bee hives agrees on one point: a successful bee move is an uneventful one! Moving bees is a relatively easy job if you know the right way to do it. Here are some suggestions how bee hives can be moved with few problems and less effort.

WHEN TO MOVE BEES

The best time to move a colony of bees is when the temperature is above 10°C. Below that temperature, the bees cluster and any bumping and jarring can cause part of the cluster to break away. Bees shaken away may not be able to regain the cluster and many or all of them could perish.

Bees should be moved in the evening or early morning before flight has begun. Cool, rainy days with temperatures cool enough to keep bees inside the hive may also be suitable for short moves. Moving bees in complete darkness or under rainy conditions is difficult because it is easy to lose one's balance or drop the hive. Even under the best of conditions, bee hives are heavy and difficult to move. Early morning moves must go as planned because you will have less time for "adjustments" if they become necessary.

WHAT TO WEAR

Beekeepers should consider wearing protective clothing when moving bees. The best outfit to wear is a set of coveralls with a zip-on veil and elasticized cuffs. Bees crawl at night (the best time to move) and tend to get inside clothing and beneath many types of veils. Stings on the neck, face, and head seem worse in the dark or in the rain.

Gloves and boots with two pair of heavy socks should be worn. If a new beekeeper or non-beekeeper friend is helping out with a move, be sure that person is well protected and be prepared to avoid any accident.

HOW TO MOVE BEES

When moving a colony, make sure the bottom board is cleated, banded, or preferably, stapled onto the first brood chamber, hives are locked together and the cover is secured to the boxes. Special 2" staples are sold by bee supply companies. If the colony hasn't been examined in the last two or more weeks, there will be a propolis seal that keeps the boxes "glued" to one another. If the colony is handled smoothly, the boxes usually won't shift. Any jarring can cause shifting however, so do not rely on the propolis seal. As a tip, don't hammer hive staples all the way in — leave enough space to slip your hive tool under the staple to remove them. Staples should be attached one to several days before the move. Bees do not take kindly to hammering at night (or day for that matter!).

A few puffs of smoke at the hive entrance several minutes before and again 10 seconds before the hive is picked up will help keep the bees inside. Push a folded piece of heavy wire screening into the entrance. Close all other entrances with tape, grass or other secure material! Take care to treat the colonies as gently as possible. Never bump them or set them down roughly, no matter how much of a hurry you are in. Do not forget to remove the screening at the hive entrance as the last thing you do at the end of the move.

The use of smoke is the most important part of the moving job. Use it liberally. Keep the smoker well filled and tamped down, so the smoke stays cool. When you are ready to screen the hives, or to load unscreened ones into a vehicle, smoke all the entrances heavily. Wait two or three minutes for the smoke to take effect. As you put open hives into the vehicle, smoke them again after they are in place. Do not hesitate to smoke a hive any time you see bees coming out of it. The car or truck should have the lights off and the motor running while you are loading. The engine vibration helps quiet the bees.

Place the hives as close together as possible in the vehicle. This keeps them from moving around enroute to the new location. They should be tied down to hold them in place. When you tie lids, be careful that you do not split the hives open. Smoke the entire load before tying it. Face the hive entrances forward if you are moving more than three or four colonies.

When you reach your destination, leave the engine running, turn off the lights, and relight the smoker. Do not slam the doors. Smoke the hives liberally, untie them, and unload them from the vehicle. Bees in unscreened

Module 1 Honeybee Management

entrance hives may have clustered outside the entrances. If so, smoke them and wait long enough for the bees to go back into their hives. A fine spray of water will also help force them back inside their hives. In extremely hot weather or after a long, rough ride, the bees may be so heavily clustered that it would be best to wait until early morning to unload them.

MOVING BEES A SHORT DISTANCE

If you move bees more than 5-10 feet and less than 1 mile, the field bees will return to their original site rather than to their new hive location. Bees orient to their hive by physical landmarks, not by some special radar. This can create problems for the colony that loses its field force and also for the beekeeper. Family members and neighbors may not appreciate having a number of disoriented bees nearby. If you want to move a colony a short distance—for example from one side of the yard to the other—the move should be done a few feet at a time, with several days in between each leg of the journey.

Alternately, move the colony at least 1 1/2 miles away for a minimum of 10 days, then move it back to the new desired location.

MOVING BEES A LONG DISTANCE

Many beekeepers move bees to pollinate various crops or to other locations to produce honey. A truck with a relatively low flat bed is best for this. The hives should be placed so they butt up against one another. Tying down a load of bees securely is absolutely essential. Many beekeepers prefer not to screen entrances for long moves. If very hot, stop every other hour and hose the colonies with water.

There should be no shifting, not to mention dropping of the load. A hive cover that flies off a colony could go through another vehicle's windshield and cause a terrible accident. All lids should be nailed down or secured in such a way there is no possibility anything can fly off. Some states require all bee loads to be screened or netted. Colonies should not be left sitting on a stopped truck during the day. The field bees will fly out and the bees can overheat quite readily. Many people prefer to load their bees at twilight and unload them at daybreak.

The beekeeper should always put fuel in his vehicle before starting on a move. Stopping for any reason can cause problems. Be sure the vehicle is road-worthy. Tires, fan belts, etc. should be checked in advance. Being stranded is extremely unpleasant, and tow trucks and mechanics are reluctant to assist vehicles loaded with bees. Plan your route in advance and be familiar with the location where you plan to unload the colonies. Landmarks will look different at night so prepare well in advance to insure uneventful moves.

Module 1 Honeybee Management

1.31 different methods of 'clearing' bees from supers;

Canadian Clearer Board

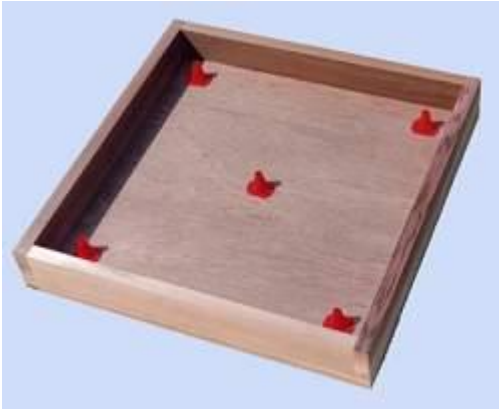

A very effective and rapid way of clearing bees. The cones are not one way valves but the bees are sufficiently disorientated not to be able to find their way back into the supers. However they should not be left on for more than six hours.

Rhombus Escape



The board provides rapid clearing in approximately one to two hours with a large void into which the bees can congregate.

Porter Bee Escape



Invented in the USA by Mr. Porter in 1891
The basic principle of its use is simplicity itself - a one way valve. Place the escapes in the crownboard slot/s with the top hole uppermost. Check that the stainless steel springs are 3mm apart. This supplies just enough tension for the bees to pass through yet are close enough together to prevent their return. Remove the queen excluder and put the crownboard in its place below the super/s to be cleared. Bees leave the super, pass through the 22mm diameter hole and into the chamber of the escape. Once there the bees have two escape routes through the springs. If used properly, bees should clear supers over a 24 hour period.

Module 1 Honeybee Management

A non-toxic blend of natural oils and herb extracts for clearing bees quickly from supers. Safe to use for both bees, beekeepers and all hive products. And it can be posted!

Using fume pads or a fume board spray Bee Quick evenly in a zig zag pattern onto the absorbent surface ensuring the liquid reaches the edges. Instructions for use: Remove all hive parts until you reach the honey supers. Place the soaked pads on top of the frames. Supers should be cleared in 2-5 minutes. Repeat as required. Best results will be obtained on a warm day when the vapours will evaporate more quickly.



Module 1 Honeybee Management

1.32 how colonies are prepared for the winter period and the principles underlying this preparation;

The importance of preparing colonies to enter the winter in a healthy state, with an adequate supply of young healthy bees and stores, cannot be overemphasised. The beekeeping year starts here, so a colony overwintered in good condition ensures that it is fit for purpose in the following spring. Recent winter colony loss investigations, both in the UK and across Europe, have clearly shown links between colony deaths and the viruses, particularly deformed wing virus, which are associated with Varroa infestations. This highlights the importance of effective and timely Varroa control. This section has been taken from the Defra Beebase leaflet [Preparing for Winter](#).

Timing

Winter preparation is usually done after the removal of the last honey crop of the year, coinciding with any varroacide treatments that may be required. This date will vary with the apiary location, but is normally from early to mid-August. However, with late flows from crops such as Heather and Himalayan balsam it may be later, and if so particular care must be taken with respect to Varroa levels and control. For instance, it may be necessary to apply a short term treatment to reduce the population of Varroa prior to colonies working late flows.

Check each colony to ensure:

Queen-right

It is better to overwinter colonies with young healthy queens, as they are less likely to die or become drone layers. Also, the brood nest of a young healthy queen is likely to be bigger later in the season than that of an old queen, thus helping to ensure an adequate replacement of the older worker bees. This is particularly important as those older bees may have shorter lives because of the pathogens associated with Varroa infestations and other bee problems. Colonies that go into winter with too few young bees are likely to dwindle rapidly in the spring. To remain productive, honey-producing colonies should be headed by queens no more than two years old. Queens with desirable traits can be kept to a greater age for breeding purposes, and many beekeepers maintain these in nucleus colonies.

Disease free

Check each colony for signs of brood and adult bee diseases. Remedial action or culling should be undertaken as appropriate. If the disease found or suspected is statutorily notifiable, i.e. European or American foulbrood, you must inform your local Bee Inspector or the National Bee Unit. Beekeepers should know the signs of these diseases and inspect colonies for foulbrood and other bee diseases throughout the season, as a minimum specifically once in the spring and once in the autumn. If colonies are small, find out why. If they are pest and disease free they can be united and re-queened. If diseased, remedial action can be taken, but culling may be a better option. Further information about brood diseases can be found in the NBU leaflet 'Foulbrood Disease of Honey Bees and other common brood disorders'.

Pest free

Check each colony for the exotic pests Small hive beetle and Tropilaelaps. If you suspect they are present you must inform your local Bee Inspector or the NBU. Further information can be found in the NBU Leaflets 'The Small Hive Beetle' and 'Tropilaelaps: parasitic mites of honeybees'.

Varroa numbers are below the treatment or damage threshold of 1,000 mites.

Varroa must be kept below the damage threshold. If beekeepers are not monitoring Varroa mite levels it is important that varroacides are used during mid-August rather than delaying treatments until September or October. This is because the bee brood population in a colony reduces significantly during July and August, whilst the Varroa population is doubling every 3 to 4 weeks. As winter bees are developing in late August and early September, it is important that the virus infections associated with Varroa are not triggered or transmitted to them. This population principal is illustrated in the graph below. If your bees forage on late crops you should monitor infestation levels and use bio-technical control methods in early summer, such as comb trapping. With proper Varroa management in early summer mite populations will be below the damage threshold during these late flows. Further details can be found in the NBU Leaflet 'Managing Varroa'.

Sufficient stores

The amount of stores required by a colony varies with the strain of bee. It is generally considered that a honey bee colony requires about 20 – 30 kg of honey to safely feed it through the winter. Larger hives headed by prolific queens may require more. When full a BS brood frame contains about 2.2 kg of honey, so assess the existing colony stores and feed the required balance using winter strength sugar syrup, i.e. 1 kg

Module 1 Honeybee Management

of white granulated sugar to 630 ml of water. Sugar syrup can be fed to supplement honey stores or as a substitute for them. Watch out for robbing bees, this can be a problem in late summer. Colonies also require ample pollen to overwinter successfully, especially to rear brood. Ensure that your overwintering bees have access to good quality pollen crops both at the end of the season and early in the following season.

Hive in sound condition, waterproof and well ventilated

Apiary sites need choosing carefully to ensure that they have good access in all weather, firm but well drained ground, sunny, not in a frost pocket, good air circulation, etc. Damp rather than cold kills bees so check hives, especially roofs, to ensure rain is shed away. It is best to ensure that your hives are off the ground on suitable stands. If your apiary site is not vulnerable to windy conditions, and you are using open mesh floors, they can be left with the floor inserts out. If not, or your hives are on solid floors, then you can lift the crown board on two-millimetre laths. Used matchsticks are excellent for this purpose.

Protected from vermin

Fit mouse guards to prevent access by small rodents, which often nest in hives during the winter. In some areas green woodpeckers can damage hives, so if this is a known problem in, or near, your apiary, place a simple cage of chicken wire around and over the hive, at least 300 mm from the hive walls to prevent damage whilst permitting bees to fly.

Monitor throughout winter

Once you have taken every precaution to ensure your colonies survival leading up to winter, it is important to remember to still monitor them during the cold months. This is particularly essential for those hives that were strong throughout the year and went into winter vigorously too. A standard British National colony will need between 20 -30 kg of food and larger hives will need more. Once they have stored all their food for winter, there are several methods that can be employed to monitor your hives:

Hefting the hive

At the end of autumn, go around and heft your hives to gauge the weight of the brood boxes. This is the weight you want to try and maintain throughout the winter and if it is getting particularly light, then chances are that you will need to feed them fondant. It is advisable to do this every other week. Around December, giving your bees a block of candy for Christmas won't hurt either.

Opening the hive

When opening the hive, you are only doing so to make a quick assessment of the cluster in relation to the stores of food. Do they have enough food? If so, are they isolated from it? This inspection should only take around 20 seconds – don't hang around.

What do you mean by are my bees isolated from food?

Even when a colony has plenty of food they may become isolated from it and end up starving. This happens when colonies move towards one end of the brood box and consume all the stores. They then isolate themselves at that end of the chamber and are unable to move the cluster to the other end where the remaining stores are. As a result they isolate themselves and starve. To prevent this from happening, every other week open the hive and have a look at the frames next to the cluster. If they are empty replace them with frames from the same hive that have food and score the honey with your hive tool. Place the frame next to the cluster and repeat with subsequent frames. If food is low give them fondant which should be placed on the top bars, directly above the cluster.

Module 1 Honeybee Management

1.33 the effect of honeybee stings and recommended first aid treatment.

When a honey bee stings someone, the sting, venom sac and venom pump are left in the skin after the bee pulls away. Most of the venom will be injected in the first 20 seconds but the pump can continue for up to two minutes. It is important to get the sting out fast to minimize the dose of venom.

It is generally thought that a bee sting should not be squeezed for fear of forcing more venom into the skin, but experiments in America have shown that as long action is taken quickly there is no difference at all between scraping, tweaking or squeezing. Time can be wasted finding a penknife or scraper, so the best method is to **scratch out the sting with a fingernail or hive tool quickly**. Then smoke the area to mask the alarm pheromone in the sting to stop any more bees from stinging in the same area.

If possible, close the hive gently, move away for a few minutes and apply a soothing lotion, such as Witch Hazel or calamine lotion onto the affected area. It is useful to keep a small bottle handy with your beekeeping tools.

On returning home, an ice pack or packet of frozen peas will help to reduce any pain or swelling resulting from the sting.

Sometimes a bee will sting through the bee suit or gloves. Then it only takes a moment to shift the clothing and dislodge the sting, smoke the area and remove the sting from the clothing.

Some beekeepers react very little to bee stings and carry on regardless but it is wiser to wear protective clothing and just take the gloves off for delicate work such as queen marking and clipping. This also has the advantage of keeping your hands clean and free from propolis. It is important to encourage beginners to wear full protective clothing while they gain confidence and find how they react to bee stings.

Some beekeepers like to get stung a few times a year to keep up their 'immunity' to stings or to 'protect' themselves from rheumatism and arthritis.

These points are debatable and must be the personal decision of the beekeeper concerned.

About 20% of beekeepers seem to have some allergic reaction to bee stings. This can range from slight swelling in the vicinity of the sting, to a generalized itching (urticaria) or anaphylaxis (generalized shock including difficulty in breathing). This very allergic group needs to be careful when working with bees to ensure that they are not stung or have prepared for an emergency. Unfortunately even beekeepers that normally show little reaction to bee stings may react adversely the next time they are stung so it is always wise to be prepared and ensure that help can be called in any emergency.

Bee stings can be avoided best by having gentle bees, choosing sensible times and weather to open the hives, by correct use of smoke and gentle handling. Frequent washing of bee suits and gloves will remove any residual sting pheromone and reduce the likelihood of subsequent bee stings. Remember, **if stung – get the sting out fast**.

Treatment for Stings

If a beekeeper has a fairly severe reaction to stings with some degree of pain and swelling, he may choose to take medication before going to the apiary. Aspirin and anti-histamines are the tablets to consider here, but **nothing should be taken without consulting your own doctor first**.

Only the GP can advise about the possible interaction with any other medication which is already being taken. If a beekeeper is likely to have severe reactions to stings his doctor might have prescribed an Epi-pen adrenaline injection to carry, for an emergency. **Only the beekeeper or a trained colleague who has been given prior permission by the beekeeper may use this injection**.

Module 1 Honeybee Management

Bee sting shock

If a person is stung and shows some distress it is important to follow a few basic guidelines. Bee sting anaphylactic shock is rare and you may never see it, but if you know what to do you can react quickly and calmly to help.

What to do

1. **Move the person away from the hives.**
2. **Scrape out the sting/s** as quickly as possible in order to stop any further injection of venom.
3. **Get the person to sit down and encourage him/her to remain calm.**
4. **If there are signs of difficult breathing, light headedness or general reaction to the sting:-**

To position the person

Conscious person.

- Loosen tight clothing at the waist and neck.
- Sit him/her on the ground, leaning against a wall, tree or the side of a car.
- Make the person as comfortable as possible to help breathing.
- The person may be short of breath, feeling sick or feeling faint and may be very frightened so stay with the person, talk quietly and encourage him/her to breathe in and out regularly.

Unconscious person.

If the person becomes unconscious, loosen tight clothing and place him/her in the **recovery position** on his/her side.

- Tilt the head back for a good airway.
- Put underneath arm behind the back.
- Check that s/he is breathing.
- Check that he has a pulse in the side of the neck.
- If there is another person, send him to flag down the ambulance.
- Do not try to give the person stung any food or drink.

If the person's heart stops or the breathing stops, resuscitation should be provided by a trained person.

Remember Anaphylactic shock is very rare, but it does happen, very quickly and calm procedure is essential.

Module 1 Honeybee Management

1.34 laying workers and drone laying queens and the conditions leading to their development;

Workers are females, they have complete reproductive systems but in a reduced form:

- Their ovaries are small, containing between 2 and 12 egg tubes, and only able to produce a few eggs compared to a queen
- They are unable to mate
- If they do lay eggs they will be unfertilised and develop into drones

In a normal colony with a laying queen there will always be a few workers with partly developed ovaries containing a few eggs. These workers do not normally lay eggs whilst there is a laying queen, if they do the eggs are not allowed to develop by the nurse bees. These eggs are laid to the side of the cell and the larva is a drone in a worker cell, so the nurse bees remove them as not appropriate.

If the queen disappears, there is no queen pheromone and all the brood is hatched the worker will start to lay.

A drone laying queen will be one that has run out or is running out of sperm and therefore cannot produce fertilised eggs. She will lay unfertilised eggs in worker cells, producing stunted drones.

Both will produce small drones and young bees will decline in numbers.

- Similarities
 - Drones laid in worker cells
 - Stunted drones in colony
- Differences
 - Queen
 - Present in DLQ,
 - LW queenless
 - Eggs
 - Single egg bottom of cell DLQ,
 - LW multiple eggs side of cell
 - Pattern
 - DLQ regular brood pattern,
 - LW laid in haphazard manner

Module 1 Honeybee Management

1.35 the signs of queenlessness and a method of confirming the condition;

Signs

- No eggs, larvae or capped brood cells (though of eggs and larvae can mean virgin queen)
- Colony more irritable than usual
- Bees seem less well organised on the frames
- Very few brood cells polished up ready for queen to lay egg
- Pollen in brood nest will be shiny from being covered with honey in order to preserve it
- Possibility of eggs from laying worker
- Stores not being built up

Method of confirming condition

- Remove a frame of eggs and young larvae from another hive
- Shake off bees
- Close up frames and add frame of foundation to outer area of brood box
- Insert frame in middle of queenless brood box
- If after several days workers make queen cells, indicates queenless